

Natural gas
Class D oil
Dual fuel

110 kW
to
1900 kW

Unical Trio

Three pass high efficiency steel boiler



- **Three-pass boiler design and large combustion chamber volume increases efficiency and reduces NO_x emissions**
- **Patented anti-condensation design permits return water temperatures of 36°C when firing with oil and 46° when firing with gas**
- **Very low stand-by losses**
- **Wide range of 2-stage gas and oil, dual-fuel and modulating gas burners available**

Contents	Page
General information	2 & 3
Dimensions	4 - 7
Technical Data	4 - 7
Installation requirements	8 & 9
Boiler wiring	10

General information

Operating principles

Trio are a range of three-pass steel boilers. The second pass of the exhaust gases is through a large diameter collector pipe that brings them back to a plenum at the front of the boiler - see figs 1 and 2 below. The final (third) pass is through boiler tubes fitted with turbulators to maximise the heat exchange. Compared with a reverse-flame steel boiler, there is less metallurgical stress on the combustion chamber. NO_x emissions are reduced (typically <120 mg/kWh) because the residence time in the burned gas area of the flame is less and the combustion chamber ratio of size to output is high at an average 1 MW : 0.7 m³.

The third-pass boiler tubes project beyond the back plate of the boiler - see fig 2. The patented "fin effect" draws the condensate film back to the weld seams that have a greater heat capacity (and so are at a higher temperature), where it is evaporated again rather than running as an acidic film down the boiler back plate. This allows the boilers to accept return water temperatures lower than the dew point of the fuel and lower than would be expected for a non-condensing boiler like the Trio, a minimum 36°C for oil and 46°C for gas. Although this may reduce or eliminate the need for back-end temperature protection, it is important to ensure a minimum flow through the boiler - see Technical data.



Fig 1 Trio boiler

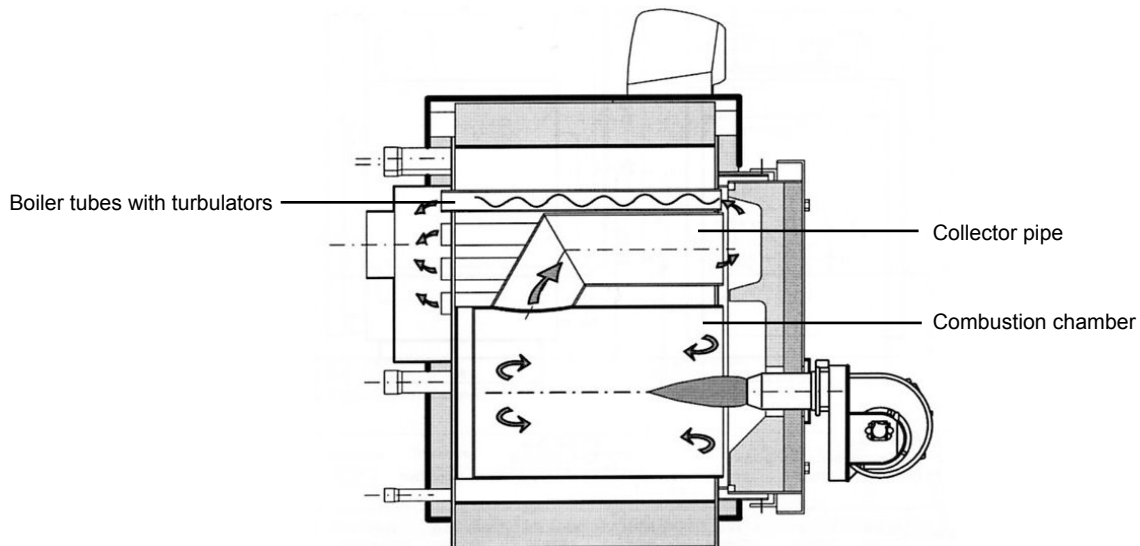

Fig 2 Passage of flue gases

Standby loss and operating loss

Standby losses are the sum of heat losses by radiation and convection from the boiler when the burner is not operating. Reducing these losses makes a significant contribution to high seasonal efficiencies. Trio boilers have 100 mm of glass wool insulation to eliminate this. They also have a twin wall combustion chamber to maximise heat to water transfer when firing.

General information

Application

The Trio range are 3-pass steel boilers, manufactured and tested in accordance with EN 303 -1. The carbon steel sheet used is to EN 10025 and the boiler tubes are of ST 37.0 steel to DIN 1626. Trio are tested in accordance with the Boiler Efficiency Directive 92/42/EEC. They are suitable for use in LTHW or MTHW heating systems with a maximum operating pressure of either 5.0 or 6.0 bar (see Technical data). Maximum system operating temperatures are 90°C for LTHW systems and 105°C for MTHW systems.

Trio boilers are supplied with Natural gas, Class D oil or Dual fuel burners with 2-stage operation. Modulating burners are optionally available.

The boiler is suitable for use in either open vented or pressurised heating systems. It is not suitable for use as a direct water heater. Where wholesome hot water is required, a matching calorifier or plate heat exchanger must be provided in the system.

Statutory requirements

Trio boilers are CE marked and must be fired by a compatible burner certified to EN676 (gas firing) or EN267 (oil firing) to comply with the Boiler (Efficiency) Directive 1993.

The installation and commissioning of the boiler must be carried out by a qualified engineer in accordance with the instructions provided.

Gas supplies and gas burners must be installed and commissioned by a qualified person, eg. a Gas Safe registered engineer.

Handling

Offloading, dry storing and placing of equipment in the boiler room is the responsibility of the installer. Lifting hooks are attached to the boiler.

Equipment must be dry stored and protected from frost. Cartons must not be crushed or otherwise damaged.

Commissioning

Clyde undertake commissioning of boilers. Commissioning charges do not include servicing during the guarantee period, although this may be carried out under service contract or to specific order. Boilers should be commissioned in line with CIBSE Commissioning Code B.

Servicing

The importance of regular maintenance cannot be over-emphasised if maximum efficiency is to be maintained. Customers are strongly advised to place the equipment under service contract immediately commissioning is complete.

Guarantee

Subject to correct handling, installation and operation, all equipment is guaranteed for twelve months from the date of despatch. Boiler heat exchangers are guaranteed for a period of two years from the date of despatch.

The guarantee is not valid if the boiler is not installed in accordance with these instructions, becomes blocked with debris and/or carbonate deposits from the system water and/or there is no documented evidence of commissioning by a competent engineer.

Boiler Log book

A boiler log book that provides a permanent record of commissioning and servicing data and measurements is supplied with every boiler. It is recommended that the owner ensures that this log book is kept safe and brought up to date on every occasion that routine or emergency work is carried out on the boiler.

Installation requirements

Electrical supply (Refer Fig 3)

A 400V 3PH supply is required for most standard burners offered. The boiler control panel requires an additional 230V 1PH supply.

If a 230V 1PH burner is being used, the fused supply should be taken to the boiler control panel only. The harness and connector supplied by Clyde will feed the burner.

The electricity supplies to the burner and boiler control panel must be wired in accordance with IEE Regulations. A separate supply and isolating switch is required for each boiler in the plant room.

All isolating switches and fuses must be provided by the installer. Burner start/run currents for fuse specification are available on request. Burner wiring diagrams and technical data are also available on request.

All connections between the boiler control panel and the burner are made through harnesses with matching plugs and sockets, supplied as standard.

Note: Fig 3 is only diagrammatic. Double pole switches with the required minimum separation must always be used.

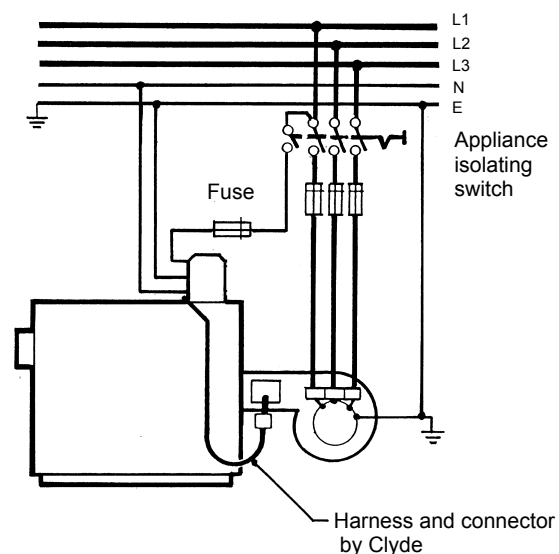
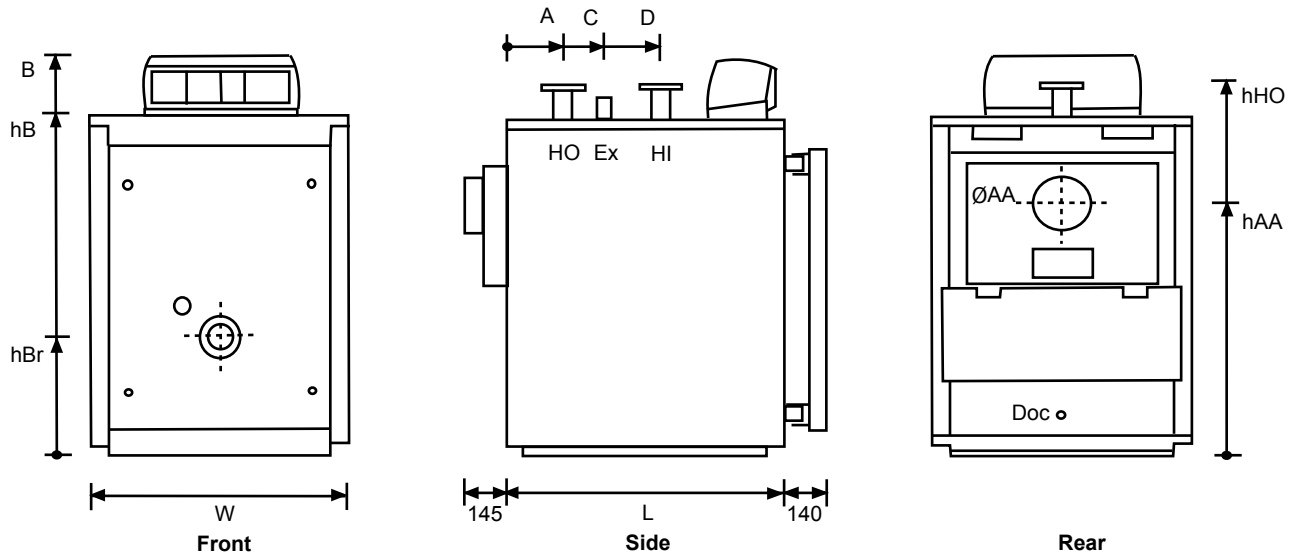

Fig 3 - Electricity supply

Dimensions and Technical data



Dimensions

Boiler model			110	150	185	225	300	380
Overall length	L	mm	885	1145	1080	1210	1275	1470
Overall width	W	mm	820	820	860	860	890	890
Overall height	B	mm	1272	1272	1372	1372	1542	1542
Boiler height	hB	mm	1082	1082	1182	1182	1352	1352
Burner height	hBr	mm	380	380	400	400	440	440
Boiler flow connection	HO	DN	50	50	65	65	80	80
Boiler return connection	HI	DN	50	50	65	65	80	80
Expansion vessel connection	Ex	Rp	1¼	1¼	1½	1½	2	2
Connection height	hHO	mm	1210	1210	1310	1310	1485	1485
HO centre from rear	A	mm	175	175	215	215	255	255
Ex centre from rear	C	mm	305	565	425	555	540	735
HI centre from rear	D	mm	490	750	675	805	855	1050
Flue spigot (inside dimension)	AA	DN	180	180	180	180	225	225
Flue spigot height	hAA	mm	748	748	828	828	928	928
Drain off cock	Doc	Rp	¾					

Technical data

Nominal heat output (full load) ncv	kW	110	150	185	225	300	380
Nominal heat input (full load) ncv	kW	120	163	202	245	327	414
Efficiency at 100% load (ncv)	%	91.7	92	91.6	91.8	91.7	91.8
Efficiency at 30% load (ncv)	%	90.7	91	91	91.2	91.3	91.5
Boiler seasonal efficiency (1)	%	82	82.2	82.1	82.3	82.4	82.5
Oil consumption (ncv)	kg/h	10.1	13.7	17	20.7	27.6	34.9
Natural gas consumption (gross cv)	m³/h	12.4	16.8	20.8	25.3	33.7	42.7
Dry weight	kg	426	503	564	621	812	906
Water content	l	204	270	285	322	408	475
Gas side resistance	Pa	74	157	118	172	118	206
Flue gas temperature rise Class D oil	°C	165	158	170	165	169	168
Flue gas mass flow (Max)	kg/h	187	254	312	378	505	644
Flue gas temperature rise Natural gas	°C	172	166	171	167	170	169
Flue gas mass flow (Max)	kg/h	176	239	307	373	497	636
CO ₂ in flue gas Class D oil	%	12.6					
CO ₂ in flue gas Natural gas	%	10.5	10.5	10.1	10.1	10.1	10
Maximum hydraulic working pressure	bar	5					

Notes: (1) Calculated from the non-domestic heating and cooling compliance guide for conformance with ADL2A and ADL2B 2010 using the formula $n_{\text{seasonal}} = 0.81n_{30\%} + 0.19n_{100\%}$

Water flow rates and hydraulic resistances

Water flow rate at 15°C temp. rise	l/s	1.75	2.39	2.94	3.59	4.78	6.06
Hydraulic resistance at 15°C temp. rise	kPa	0.08	0.1	0.18	0.2	0.35	0.53
Min water flow rate	l/s	0.67	0.92	1.13	1.38	1.83	2.32
Hydraulic resistance at min flow rate	kPa	1	1	1	1	1	1

Dimensions and Technical data

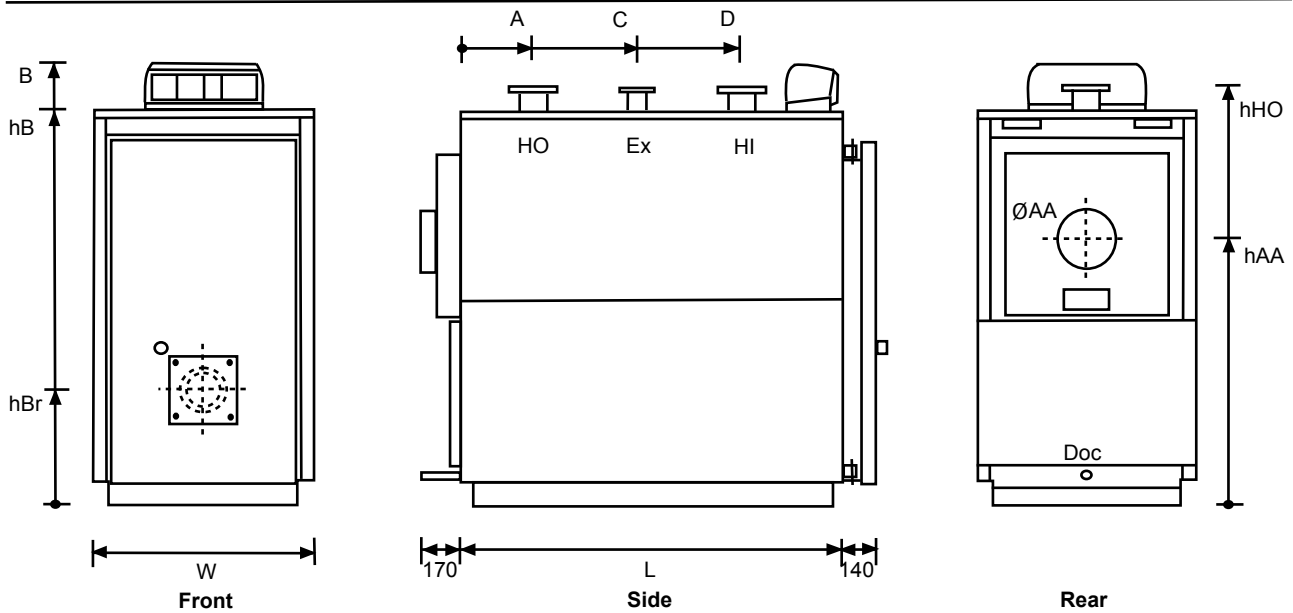

Dimensions

Boiler model			500	630	730
Overall length	L	mm	1605	1800	1995
Overall width	W	mm	920	920	920
Overall height	B	mm	1835	1835	1835
Boiler height	hB	mm	1645	1645	1645
Burner height	hBr	mm	480	480	480
Boiler flow connection	HO	DN	100		
Boiler return connection	HI	DN	100		
Expansion vessel connection	Ex	DN	65		
Connection height	hHO	mm	1740	1740	1740
HO centre from rear	A	mm	298	298	298
Ex centre from rear	C	mm	733	928	1123
HI centre from rear	D	mm	1173	1368	1563
Flue spigot (inside dimension)	AA	DN	250	250	250
Flue spigot height	hAA	mm	1028	1028	1028
Drain off cock	Doc	Rp	1½		

Technical data

Nominal heat output (full load) ncv	kW	500	630	730
Nominal heat input (full load) ncv	kW	545	686	795
Efficiency at 100% load (ncv)	%	91.7	91.8	91.8
Efficiency at 30% load (ncv)	%	91.5	91.4	91.4
Boiler seasonal efficiency (1)	%	82.5	82.4	82.4
Oil consumption (ncv)	kg/h	45.9	57.8	67
Natural gas consumption (gross cv)	m³/h	56.2	70.8	82
Dry weight	kg	1295	1430	1560
Water content	l	708	794	871
Gas side resistance	Pa	343	441	480
Flue gas temperature rise Class D oil	°C	171	170	171
Flue gas mass flow (Max)	kg/h	842	1060	1228
Flue gas temperature rise Natural gas	°C	175	174	180
Flue gas mass flow (Max)	kg/h	813	1024	1155
CO ₂ in flue gas Class D oil	%	12.6		
CO ₂ in flue gas Natural gas	%	10.3	10.3	10.6
Maximum hydraulic working pressure	bar	5		

Notes: (1) Calculated from the non-domestic heating and cooling compliance guide for conformance with ADL2A and ADL2B 2010 using the formula $n_{\text{seasonal}} = 0.81n_{30\%} + 0.19n_{100\%}$

Water flow rates and hydraulic resistances

Water flow rate at 15°C temp. rise	l/s	8	10	11.6
Hydraulic resistance at 15°C temp. rise	kPa	0.15	0.23	0.33
Min water flow rate	l/s	3.1	3.9	4.5
Hydraulic resistance at min flow rate	kPa	1	1	1

Dimensions and Technical data

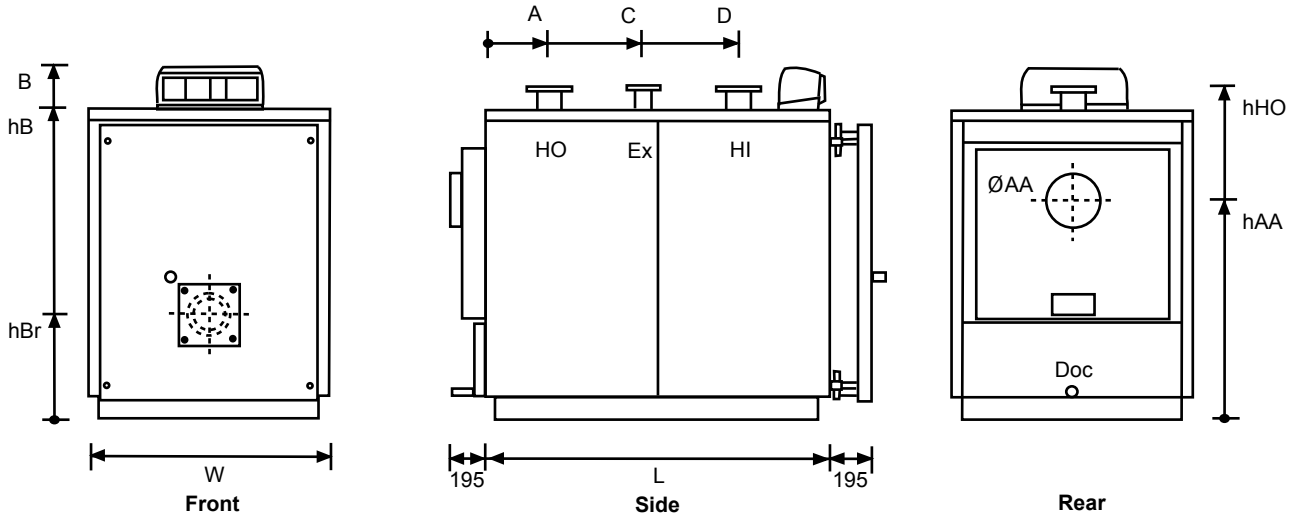

Dimensions

Boiler model			840
Overall length	L	mm	2115
Overall width	W	mm	1122
Overall height	B	mm	1622
Boiler height	hB	mm	1432
Burner height	hBr	mm	480
Boiler flow connection	HO	DN	100
Boiler return connection	HI	DN	100
Expansion vessel connection	Ex	DN	65
Connection height	hHO	mm	1540
HO centre from rear	A	mm	298
Ex centre from rear	C	mm	945
HI centre from rear	D	mm	1683
Flue spigot (inside dimension)	AA	DN	250
Flue spigot height	hAA	mm	1025
Drain off cock	Doc	Rp	1¼

Technical data

Nominal heat output (full load) ncv	kW	840
Nominal heat input (full load) ncv	kW	915
Efficiency at 100% load (ncv)	%	91.8
Efficiency at 30% load (ncv)	%	91.5
Boiler seasonal efficiency (1)	%	82.5
Oil consumption (ncv)	kg/h	77.1
Natural gas consumption (gross cv)	m³/h	94.4
Dry weight	kg	1581
Water content	l	932
Gas side resistance	Pa	568
Flue gas temperature rise Class D oil	°C	173
Flue gas mass flow (Max)	kg/h	1228
Flue gas temperature rise Natural gas	°C	181
Flue gas mass flow (Max)	kg/h	1329
CO ₂ in flue gas Class D oil	%	12.6
CO ₂ in flue gas Natural gas	%	10.6
Maximum hydraulic working pressure	bar	5

Notes: (1) Calculated from the non-domestic heating and cooling compliance guide for conformance with ADL2A and ADL2B 2010 using the formula $n_{\text{seasonal}} = 0.81n_{30\%} + 0.19n_{100\%}$

Water flow rates and hydraulic resistances

Water flow rate at 15°C temp. rise	l/s	13.4
Hydraulic resistance at 15°C temp. rise	kPa	0.52
Min water flow rate	l/s	5.1
Hydraulic resistance at min flow rate	kPa	1

Dimensions and Technical data

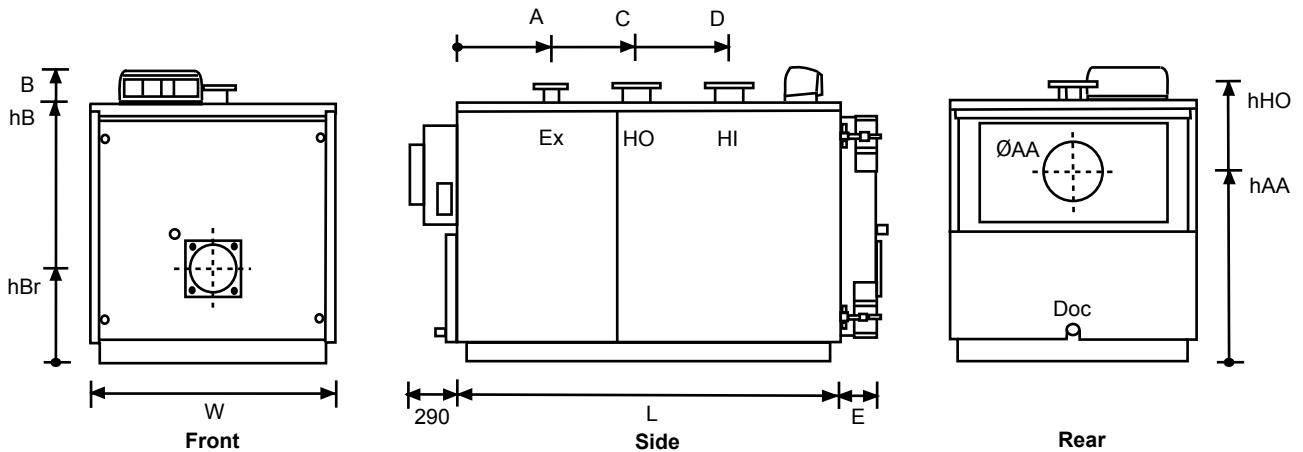

Dimensions

Boiler model			1100	1320	1600	1900
Overall length	L	mm	2282	2652	2692	3014
Overall width	W	mm	1462	1462	1622	1622
Overall height	B	mm	1732	1732	1892	1892
Boiler height	hB	mm	1542	1542	1702	1702
Burner height	hBr	mm	565	565	605	605
Boiler flow connection	HO	DN	150	150	175	175
Boiler return connection	HI	DN	150	150	175	175
Expansion vessel connection	Ex	DN	80	80	100	100
Connection height	hHO	mm	1650	1650	1810	1810
Ex centre from rear	A	mm	561	561	661	662
HO centre from rear	C	mm	1071	1441	1331	1652
HI centre from rear	D	mm	1621	1991	2031	2352
Door depth	E	mm	230	230	260	260
Flue spigot (inside dimension)	AA	DN	350	350	400	400
Flue spigot height	hAA	mm	1120	1120	1245	1245
Drain off cock	Doc	Rp	1½			

Technical data

Nominal heat output (full load) ncv	kW	1100	1320	1600	1900
Nominal heat input (full load) ncv	kW	1198	1438	1743	2070
Efficiency at 100% load (ncv)	%	91.8	91.8	91.8	91.8
Efficiency at 30% load (ncv)	%	91.6	91.6	91.6	91.5
Boiler seasonal efficiency (1)	%	82.6	82.6	82.6	82.5
Oil consumption (ncv)	kg/h	101	121.2	147	174.5
Natural gas consumption (gross cv)	m³/h	123.6	148.3	179.8	213.5
Dry weight	kg	2444	2965	3685	4089
Water content	l	1580	1791	2297	2496
Gas side resistance	Pa	608	833	539	715
Flue gas temperature rise Class D oil	°C	174	175	176	177
Flue gas mass flow (Max)	kg/h	1850	2221	2692	3197
Flue gas temperature rise Natural gas	°C	182	183	184	185
Flue gas mass flow (Max)	kg/h	1740	2088	2531	3006
CO ₂ in flue gas Class D oil	%	12.6			
CO ₂ in flue gas Natural gas	%	10.6			
Maximum hydraulic working pressure	bar	6			

Notes: (1) Calculated from the non-domestic heating and cooling compliance guide for conformance with ADL2A and ADL2B 2010 using the formula $n_{\text{seasonal}} = 0.81n_{30\%} + 0.19n_{100\%}$

Water flow rates and hydraulic resistances

Water flow rate at 15°C temp. rise	l/s	17.5	21	25.5	30.3
Hydraulic resistance at 15°C temp. rise	kPa	0.21	0.3	0.28	0.39
Min water flow rate	l/s	6.7	8.1	9.8	11.6
Hydraulic resistance at min flow rate	kPa	1	1	1	1

Installation requirements

Boiler location (See fig 4)

The location chosen for the boiler(s) must be frost free, provide for a satisfactory flue system and an adequate air supply for combustion and ventilation. Adequate access is necessary for boiler and burner servicing.

Boilers must not be installed in areas where inflammable vapours are likely to be present. To avoid damage to the boilers, contamination of the combustion air by high levels of dust or halogenated hydrocarbons (eg. Solvents, spray can propellants, cleaning agents, adhesives, etc) must be avoided.

Boilers should be installed on a plinth which is at least 50mm high and is smooth and level. The plinth must support the entire boiler base, eg minimum dimensions will be W x L from pages 4 to 7. (NB : For some burners with acoustic shrouds the plinth may need to be higher - refer Clyde Sales Office).

Burners

Boilers can be supplied with two stage Natural gas, Class D oil or Dual fuel burners. Modulating burners are also available with load-matching control equipment. A choice of burner makes is available.

Biomass pellet burners are also available for some models - refer to Clyde for details.

Fuel specification

Natural gas (GCV 38.76 MJ/m³) with a minimum gas inlet pressure according to the burner model specified.

BS2869 Class D oil (35 sec). Advice should be sought from the oil supplier regarding the storage of Class D oil.

Fuel supply pipework

Install gas or oil supply pipe(s) and service valve(s) so as to allow free access to the boiler and full opening of the furnace door without removing the burner from the boiler door (see below).

Commissioning of the gas supply pipework and components must be carried out by a qualified person, eg, a Gas Safe registered engineer. The gas meter and supply must be sited in accordance with the requirements of BS6400.

Plant room layout

When planning the layout of the boiler room, allowance must be made for opening the boiler door, boiler cleaning and maintenance. The boiler door may be hinged from the right (as illustrated) or the left.

The table below shows the minimum clearances around the boiler.

Dimension W2 = length of burner + 200mm.

Dimension L1 = length of boiler (recommended) for cleaning

Dimension W1 = 900mm for access to rear boiler clean-out

Dimension W3 = minimum 100mm

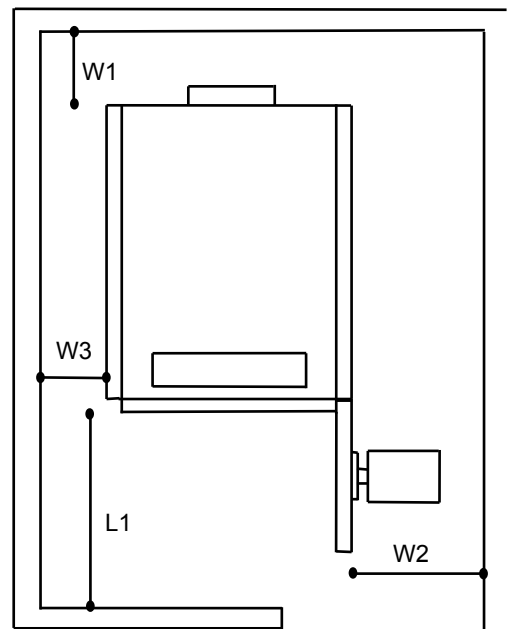

Fig 4 Boiler clearances

Installation requirements

Air supply

Air for ventilation and combustion must be provided for gas fired boilers in accordance with either BS 6644:2005 or IGEM/UP/10 (up to 1.8 MW net input). Air supply for oil fired boilers must conform to BS 5410 : Part 2.

Chimney design

The Trio boiler is designed to operate with a pressurised combustion chamber and the chimney is not required to assist the burner in overcoming the boiler resistance. The chimney must cater for the total internal resistance of the flue system from each boiler outlet and not impose an additional load on the burner.

Water circulation (See figs 5 & 6)

The Trio boiler is designed to accept unusually low return water temperatures for a non-condensing boiler. Water temperatures as low as 46°C (gas firing) or 36°C (oil firing) can be returned to the boiler. At these temperatures, condensation will occur in the third pass (the boiler tubes). Whereas a condensing boiler would utilise the latent heat of condensation, the Trio re-evaporates the condensate to protect the steel boiler from acidic condensate. Whilst there is considerable tolerance in these return temperatures, these are minimum figures and the boiler may need to be protected against lower return temperatures. It is also important that a minimum flow be

maintained through the boiler at all times - see Technical data on pages 4 to 7. A pump overrun facility is necessary to ensure that water circulation is maintained for at least three minutes after the boiler is switched off.

There are several ways of providing boiler protection and minimum flow rates, eg shunt pumps, primary loops, etc. A typical boiler pump and 3-port valve arrangement is shown in fig 5.

For multi-boiler systems a 'reverse return' pipework configuration is required to ensure equal distribution of water flow through the boilers.

Water treatment

Whenever a new boiler is connected to an existing system, the pipework must be thoroughly cleaned and flushed. Clyde recommend that a permanent means of filtration be fitted into the return pipework, such as a sludge trap (which can be supplied by Clyde), hydrocyclone or full flow duplex filters. The boiler guarantee will be invalid if waterways are blocked by debris or carbonate deposits. Long term water treatment is essential to the economic operation and life of both new and refurbished heating systems.

For full information on cleaning, flushing and protecting hot water systems, refer to BSRIA Application Guide AG 1/2001.

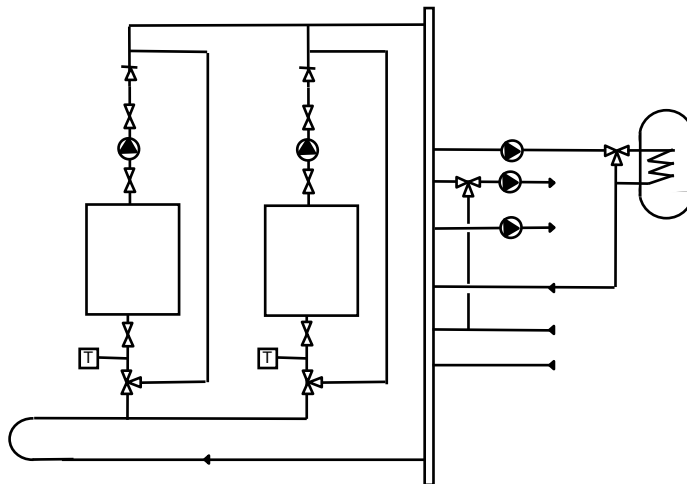

Fig 5 Multiple boilers with individual pumps

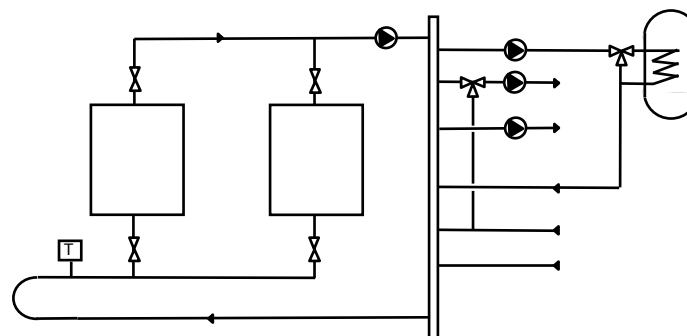

Fig 6 Alternative arrangement for boiler protection with a primary loop

Boiler control panel

Control panel 21057 (see fig 7) provides either 1-stage burner control for on/off, modulating or LFS operation or 2-stage burner control for high/low operation via a dual-thermostat with a fixed differential of 6°C. There is an overheat limit thermostat and a switch for control of a circulating pump via a relay (not supplied). If this pump control is used, there is a minimum temperature thermostat within the module that will hold back the pump until the boiler reaches 50°C.

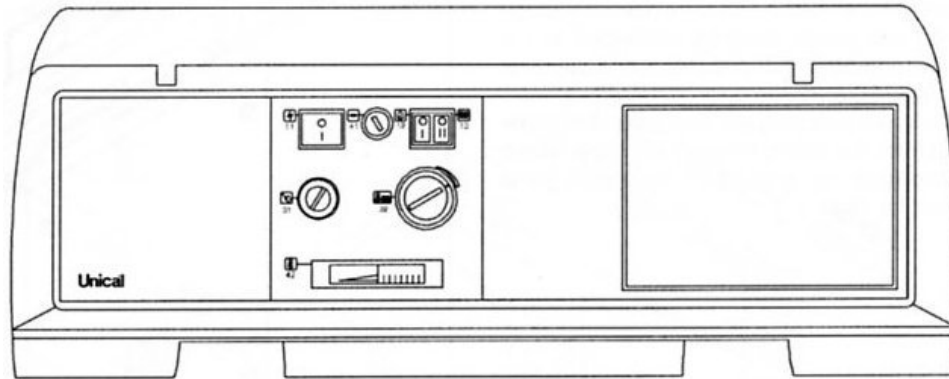

Fig 7 Boiler control panel 21057

Control panel 21057 standard components

Illuminated on/off switch
4A fuse

Overheat limit thermostat and manual reset
Boiler on/off switch

Circulating pump on/off switch (relay required)
Control thermostat (range 60°C to 90°C)
Thermometer

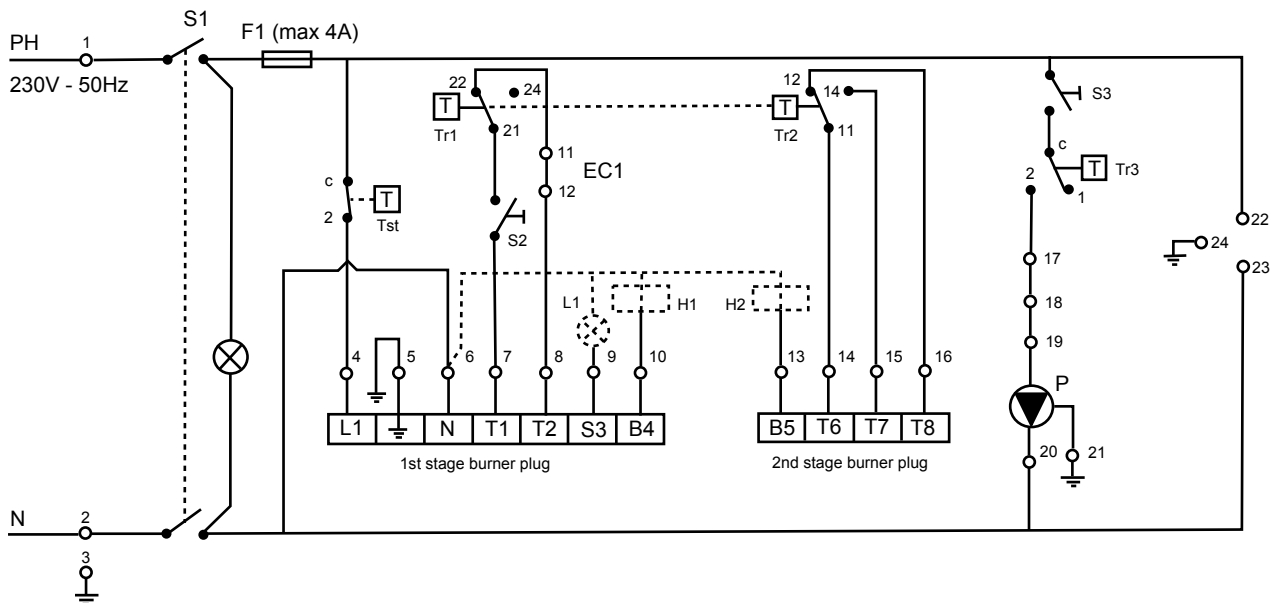

Fig 8 wiring schematic

Key to fig 8 wiring schematic

EC1 External volt-free control (eg timeclock)
H1 External stage 1 hours run counter
H2 External stage 2 hours run counter
L1 External remote lock-out lamp
P External circulating pump
S1 Panel on/off switch

S2 Burner on/off switch
S3 Circulating pump on/off switch
Tst Boiler overheat thermostat (100°C)
Tr1 Stage 1 thermostat (60°C to 90°C)
Tr2 Stage 2 thermostat (54°C to 84°C)
Tr3 Minimum temperature thermostat (50°C)

This publication is issued subject to alteration or withdrawal without notice. The illustrations and specifications are not binding in detail. All offers and sales are subject to the Company's current terms and conditions of sale, a copy of which is available on request.

Clyde Energy Solutions Ltd

Units 13 - 14 Charlwoods Rd
East Grinstead
West Sussex RH19 2HU
t : 01342 305550
f : 01342 305560
e : info@clyde4heat.co.uk
w : clyde4heat.co.uk

EDS 790/2
November 2011