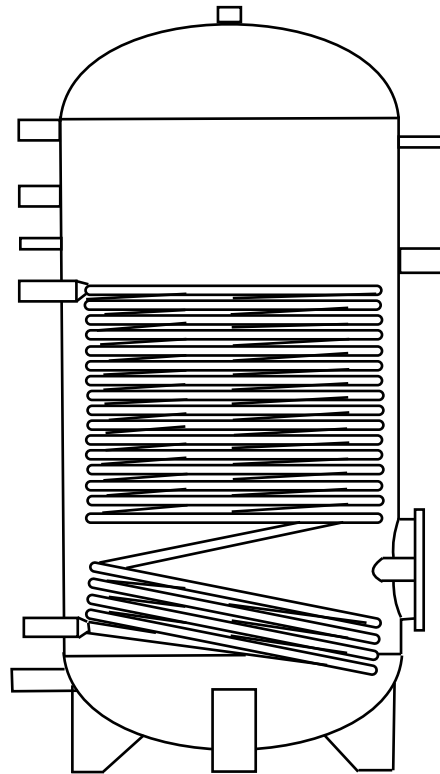

Clyde Stainless Steel HWS

bespoke stainless steel calorifiers
up to 50,000 litres storage

**Contents****Page**

General information	2
Schematic pipework	3
Calorifier quotation	4 - 7

- Fully-insulated bespoke stainless steel calorifiers with a wide range of storage capacity from 150 to 50,000 litres
- Horizontal, vertical, direct or indirect units fabricated in the UK
- Electric immersion heaters are also offered to ensure hot water is always available

General information

Description

Clyde stainless steel calorifiers are fabricated from heavy gauge steel (a minimum of 2 mm). They are suitable for a maximum working pressure of 3.5 bar on the secondary side and 5 bar on the primary side (coils or heater batteries). They are tested to 1.5 x maximum working pressure. The calorifiers are finished with a durable and flexible canvas jacket with 50mm or 100mm Type 'M' foam insulation. Due to stockholding, vessels with a diameter of 600, 800, 960, 1100, 1400, 1700 or 2200 mm can be fabricated in the shortest time.

System Design

Publications relating to the storage of wholesome hot water and the control of legionella bacteria in water systems are available from the Health and Safety Executive (eg Approved Code of Practice and Guidance L8 from HSE Books) and the Chartered Institution of Building Services Engineers (eg TM13 from CIBSE). These publications give guidance on system design including minimum stored water temperatures and the prevention of temperature stratification in calorifiers and storage tanks.

Application

The Clyde range of calorifiers generally have indirect primary heating coils and are designed for use as hot water storage vessels in open vented or direct feed wholesome water supplies with a conductivity greater than 100 $\mu\text{S}/\text{cm}$ (micro-siemens / cm). They are not suitable for use in saline, de-ionised or chemically treated water systems.

Calorifiers must be installed so as to comply with the requirements of the Water Byelaws Regulations and BS 6700:2006 and must be installed by a competent person. For use as an unvented water heater in a domestic situation and with a storage volume of between 151 and 500 litres, the installation must conform with G3 building regulations.

Location

The location of Clyde calorifiers must provide adequate space for pipework connections and jacket fitting. The location chosen must permit servicing and maintenance of the calorifier and auxiliary equipment, such as de-stratification and circulation pumps and electric immersion heaters. A specially built plinth is not necessary but calorifiers should be installed on a level surface that is capable of supporting the weight of the filled calorifier and auxiliary equipment.

Storage & handling

To avoid damage to the vessel and jacket, calorifiers must always be handled and stored in the vertical or horizontal plane for which they have been designed and in a dry, frost-free environment.

Primary Water Circulation

To achieve the rating and flow rates it is important that the primary circulating pump is sized in accordance with the design data for the vessel.

Secondary Water Circulation

A secondary water return connection is usually provided to allow recirculation back to the calorifier and ensure that hot water is constantly available at the service outlets - see the schematic pipework arrangement on page 3.

Maintenance

Filled and unheated calorifier vessels must never be allowed to freeze. After installation the secondary water storage must be filled before heated water is permitted to flow through the primary coil.

The internal surfaces of the vessel must be inspected periodically and kept free of hard water calcium deposits.

Guarantee

Clyde stainless steel calorifiers are designed for use with wholesome water supplies only. The guarantee is invalid if the calorifier is used on other types of water supply, eg, saline, de-ionised, chemically treated, etc.

Subject to correct handling, installation, use and maintenance, and providing that the conductivity of the water supply is greater than 100 $\mu\text{S}/\text{cm}$, Clyde calorifier vessels are guaranteed for 2 years from the date of delivery. The guarantee will become invalid if :

- The vessel becomes blocked with carbonate deposits.
- The water supply is not in accordance with the requirements stated above
- The vessel is exposed to pressures or temperatures that exceed those it has been designed for

Electric immersion heaters

Optional electric immersion heaters are available. A standard 67 mm boss is suitable for up to 18 kW (max 3 kW for a 1-phase 230 Vac supply). Refer to Clyde for availability of larger output heaters.

Schematic pipework arrangement

The pipework schematic of Fig 1 illustrates an unvented hot water storage system that generally complies with the Water Supply (Water Fittings) Regulations 1999, BS 6700:2006 and Part G of The Building Regulations. The calorifier is supplied without a controller, so a temperature control thermostat and high-limit thermostat will additionally be required. Alternatively, an open-vented system may be used.

Although fig 1 shows the secondary circulation (bronze) pump on the return to the calorifier, it is not unknown for this pump to be fitted in a small loop on the secondary water flow, where it can directly assist the flow without restricting the bore of the pipework.

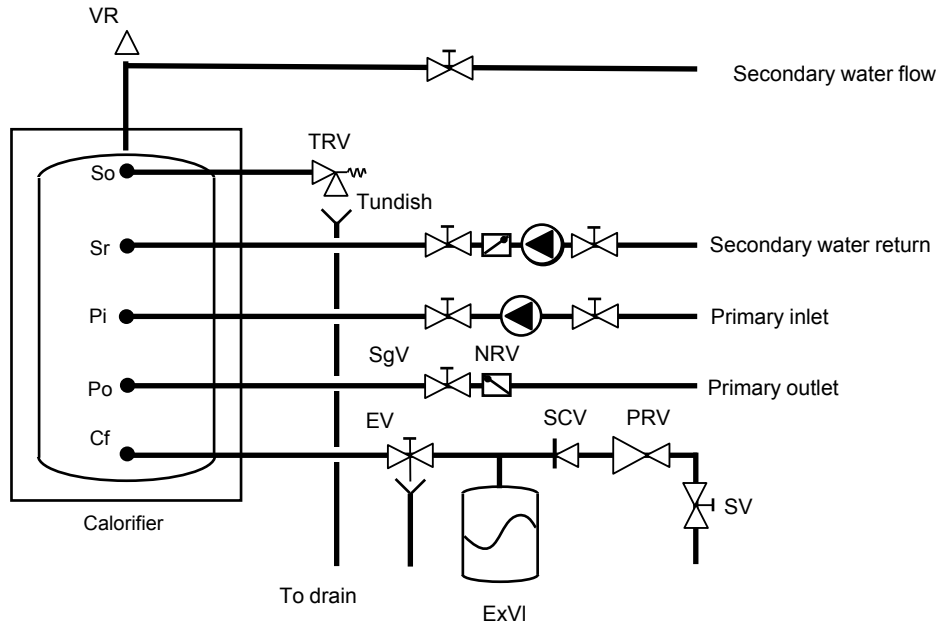

Fig 1 Pipework schematic for an unvented hot water storage system

Key to fig 1

SV	Stop cock with drain tap
PRV	Pressure reducing valve (if required)
SCV	Single check valve
ExVI	Expansion vessel
EV	Expansion valve with discharge to tundish
NRV	Non-return valve
SgV	Service valve
TRV	Temperature relief valve or Temperature and Pressure relief valve with discharge to tundish
VR	Vacuum Relief valve
Cf	Cold feed
Pi	Heating primary inlet
Po	Heating primary outlet
So	Secondary outlet
Sr	Secondary return

Note; a temperature control thermostat and a high limit thermostat (not supplied) are additionally required for compliance

Calorifier quotation

Calorifier quotation procedure

The form on page 5 is a template for your data so that our quotation can be as accurate as possible. If your requirement is for a vertical indirect calorifier, please refer to figs 2a and 2b on page 6. If the connections shown are unsuitable or you require a horizontal calorifier, please mark approximate connection positions on the outlines on fig 3 (vertical) or fig 4 (horizontal) on page 7.

Table 1 below gives typical guideline dimensions for various calorifiers, using diameters of 600, 800, 960, 1100, 1400, 1700 and 2200mm. All calorifier sizes up to a storage of 50,000 litres are available, but these sizes are based on stockholding, so will be fabricated more quickly. Clyde's Estimating Department will be able to advise on the delivery time for your specific project.

The quoted price includes delivery to a UK mainland site.

Once completed, please fax or email both the form and relevant diagram to the Clyde Estimating Department at fax 01342 305560 or info@clyde4heat.co.uk. If you require any assistance at all, please call 01342 305550.

Once an order has been placed, an autoCad drawing will be provided for your verification before fabrication.

Storage volume (litres)	Dimensions (mm)
450	1800 x 600
600	2300 x 600
700	1500 x 800
800	1700 x 800
1000	1450 x 960
1400	2400 x 960
2000	2200 x 1100
2500	2700 x 1100

Table 1 Typical guideline dimensions for various calorifiers

From: _____ Company: _____

Address: _____

Project Reference: _____

Telephone / Fax: _____

Email: _____

Please fax or email this form, together with pages 6 and / or 7, to Clyde Estimating Department at fax **01342 305560** or **info@clyde4heat.co.uk** or call **01342 305550** for assistance.

Dimensions and Technical Data form

H	Overall height (m)	
D	Overall diameter (m)	
d	Vessell diameter (m)	
Vol	Secondary storage (litres)	
Cf	Cold feed diameter	
Cf H	Cold feed height from base (m)	
So	Secondary HWS outlet diameter	
So H	Secondary HWS height from base (m)	
Sr	Secondary return diameter	
Sr H	Secondary return height from base (m)	
Pf	Primary flow diameter	
Pf H	Primary flow height from base (m)	
Pr	Primary return	
Pr H	Primary return height from base (m)	
Coli	Primary coil rating (kW) (1)	
Hc	Handhole cover diameter	
Hc H	Handhole cover height from base (m)	
Sv	Safety valve	
Th	Thermometer	
Pg	Pressure gauge connection	
Av	Anti-Vacuum	
Doc	Drain connection	
Ei	Electric immersion heater (kW) see page 2	
Bd	Burst disc	

	Vented or unvented vessel?	
	Maximum primary (coil) working pressure	5 bar
	Maximum secondary working pressure	3.5 bar

Note (1) Use kW = (litres hour⁻¹ x temperature rise (°C) / (14.3 x minutes)

Calorifier quotation

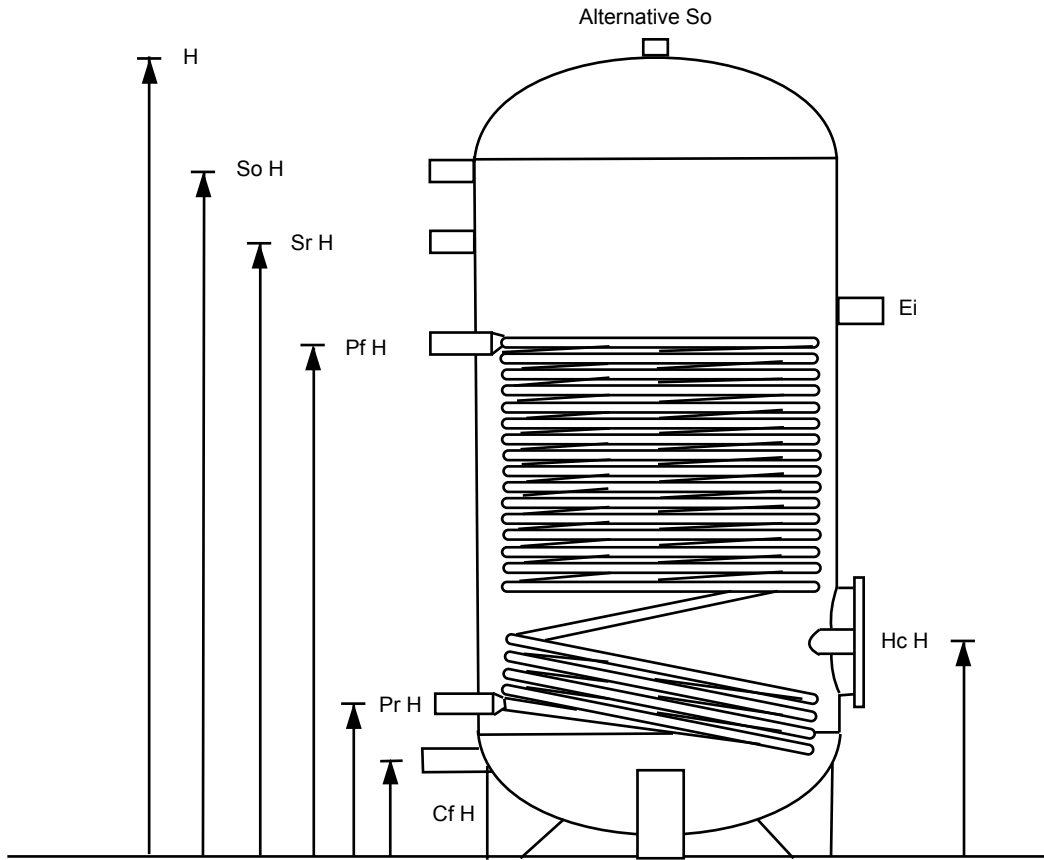

Fig 2a Elevation of typical calorifier

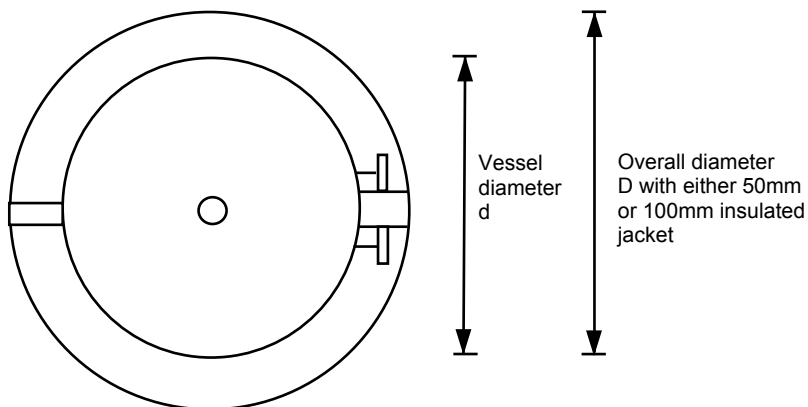

Fig 2b Plan of typical calorifier

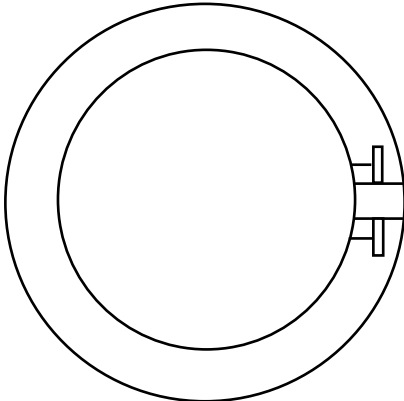

Fig 3a Plan of vertical calorifier

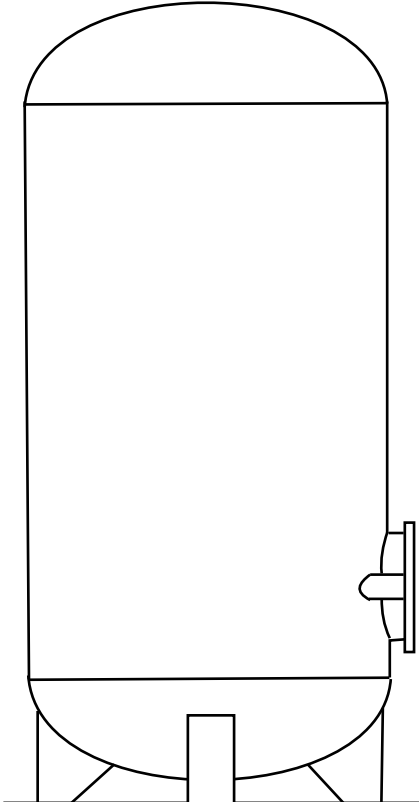

Fig 3b Elevation of vertical calorifier

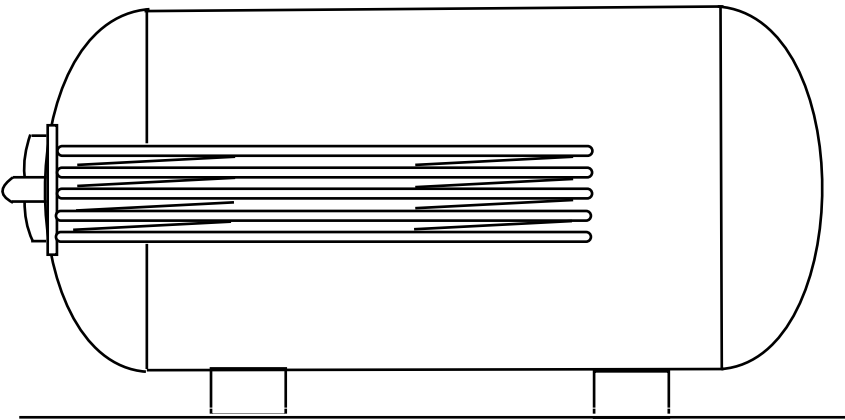

Fig 4a Elevation of horizontal calorifier

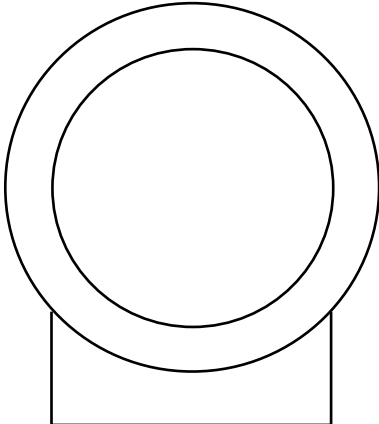

Fig 4b End section of horizontal calorifier

This publication is issued subject to alteration or withdrawal without notice. The illustrations and specifications are not binding in detail. All offers and sales are subject to the Company's current terms and conditions of sale, a copy of which is available on request.

Clyde Energy Solutions Ltd

Units 13 - 14 Charlwoods Rd
East Grinstead
West Sussex RH19 2HU
t : 01342 305550
f : 01342 305560
e : info@clyde4heat.co.uk
w : clyde4heat.co.uk

EDS 821/1
April 2011