

Pembroke

Cast iron radiators

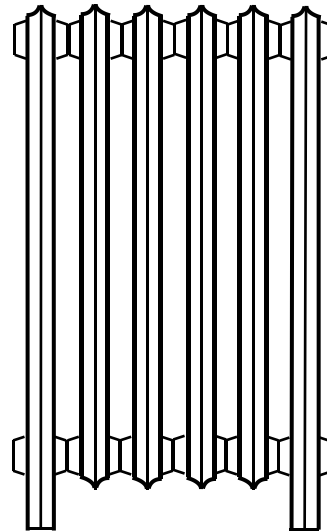
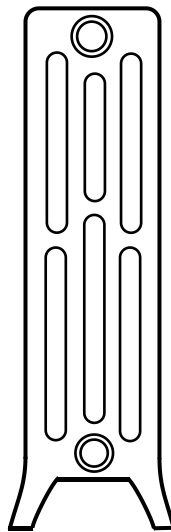

Contents	Page
General information	2
Emission rates	2
Dimensions	2
Quick sizing charts	3
Connections	4
Enclosures	4
Block make-up	5
Assembling	5
Painting	6

General information

Pembroke models

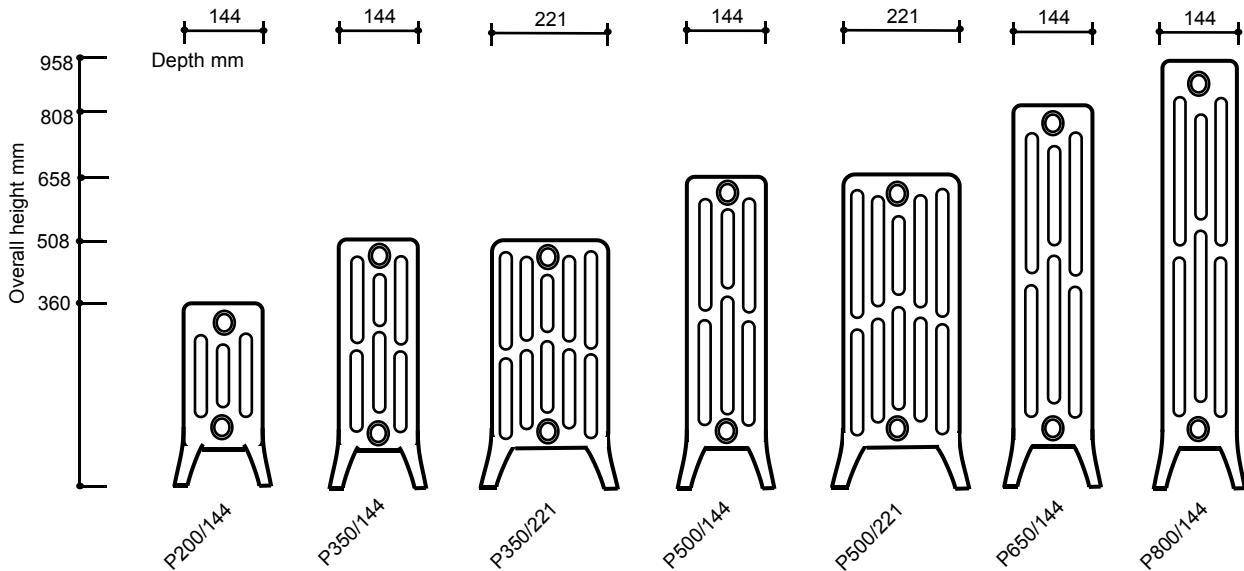

Manufacturing standards

Clyde Pembroke radiators are tested and supplied in accordance with BS EN 442-1:1995. As required by this Standard, emission rates are quoted for the standard thermal output of $\Delta T=50$ (75/65/20°C) with the relevant exponent of excess temperature.

Heat emission rates

For convenience the emission rates are also quoted for typical United Kingdom applications of $\Delta T=55.5$ (82/71/21°C) and $\Delta T=60$ (90/70/20°C).

Different water and/or room temperatures will change the emission rate of the radiator. The method of calculation and correction factors for various temperatures are given in Clyde's radiator emission guide EDS 658, available on request.

The emission rates stated are all based upon TBOE (top & bottom opposite end) connections.

Application

Clyde Pembroke radiators are suitable for use in either open vented or sealed heating systems with a maximum operating pressure of 6 bar.

Materials

Pembroke radiators are manufactured from grey cast iron complying with ISO 185. Sections are supplied with a primer coat which requires paint finishing on site.

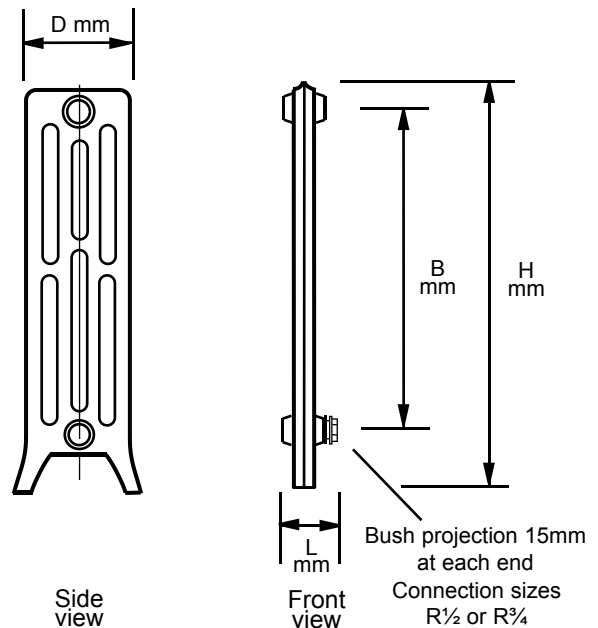

Dimensions - refer table below

Section emission rates and details

Model	BS EN 442		Emission rates		Recommended Max. No. sections	Section details							
	75/65/20°C		82/71/21°C			90/70/20°C		Overall Length ★ L mm	Overall height H mm	Bore centres B mm	Depth D mm	Dry weight kg	Water content litres
	DT50 watts	Exponent	DT55.5 watts	DT60 watts									
P200/144	43.0	1.30	49.2	54.5	40	60.5	360	200	144	3.21	0.40	0.10	
P350/144	65.0	1.30	74.4	82.4	40	60.5	508	350	144	4.50	0.70	0.15	
P500/144	93.0	1.30	106.5	117.8	40	60.5	658	500	144	5.60	0.88	0.21	
P650/144	108.0	1.30	123.7	136.9	40	60.5	808	650	144	7.10	1.00	0.26	
P800/144	139.0	1.30	159.2	176.2	34	60.5	958	800	144	8.00	1.14	0.32	
P350/221	95.0	1.30	108.8	120.4	40	60.5	508	350	221	6.60	1.00	0.23	
P500/221	133.0	1.30	152.3	168.6	35	60.5	658	500	221	8.10	1.20	0.32	

★ Overall section length = section + joint ring

SI conversion factor : 1 watt = 3.412 Btu/h

Quick sizing charts

For exact emissions, refer table, page 2

Model	watts per section	Radiator emission in kilowatts											
		0.6	0.8	1.0	1.25	1.5	1.75	2.0	2.5	3.0	4.0	5.0	6.0
		Nearest number of sections required											
P200/114	43.0	14	19	23	29	35	41	47	—	—	—	—	—
P350/144	65.0	9	12	15	19	23	27	31	38	—	—	—	—
P500/144	93.0	6	9	11	13	16	19	22	27	32	—	—	—
P650/144	108.0	6	7	9	12	14	16	19	23	28	37	—	—
P800/144	139.0	4	6	7	9	11	13	14	18	22	29	—	—
P350/221	95.0	6	8	11	13	16	18	21	26	32	—	—	—
P500/221	133.0	5	6	8	9	11	13	15	19	23	30	—	—

ΔT50

Inlet 75°C
 Outlet 65°C
 Room 20°C
 BS EN 442-1:1995

Model	watts per section	Radiator emission in kilowatts											
		0.6	0.8	1.0	1.25	1.5	1.75	2.0	2.5	3.0	4.0	5.0	6.0
		Nearest number of sections required											
P200/114	49.2	12	16	20	25	30	36	—	—	—	—	—	—
P350/144	74.4	8	11	13	17	20	24	27	34	40	—	—	—
P500/144	106.5	6	8	9	12	14	16	19	23	28	38	—	—
P650/144	123.7	5	6	8	10	12	14	16	20	24	32	40	—
P800/144	159.2	4	5	6	8	9	11	13	16	19	25	31	—
P350/221	108.8	6	7	9	11	14	16	18	23	28	37	—	—
P500/221	152.3	4	5	7	8	10	11	13	16	20	26	33	—

ΔT55.5

Inlet 82°C
 Outlet 71°C
 Room 21°C

Model	watts per section	Radiator emission in kilowatts											
		0.6	0.8	1.0	1.25	1.5	1.75	2.0	2.5	3.0	4.0	5.0	6.0
		Nearest number of sections required											
P200/114	54.5	11	15	18	23	28	32	37	—	—	—	—	—
P350/144	82.4	7	10	12	15	18	21	24	30	36	—	—	—
P500/144	117.8	5	7	8	11	13	15	17	21	25	34	—	—
P650/144	136.9	4	6	7	9	11	13	15	18	22	29	37	—
P800/144	176.2	—	5	6	7	9	10	11	14	17	23	28	34
P350/221	120.4	5	7	8	10	12	15	17	21	25	33	—	—
P500/221	168.6	4	5	6	7	9	10	12	15	18	24	30	—

ΔT60

Inlet 90°C
 Outlet 70°C
 Room 20°C

Guarantee

Subject to correct handling, installation, water treatment and operation, Clyde Pembroke radiators are guaranteed against manufacturing defects for 10 years from date of despatch.



Packing, handling & site work

Radiator sections are supplied on pallets to facilitate handling.

Accessories are delivered packed separately for fitting by the installer. It is important that radiators are protected from the elements during offloading and are stored in dry and adequately heated premises. After radiators have been removed from their pallets, they must be kept vertical whilst being carried to their installation locations to avoid damage to the section joints - refer page 6.

Radiators are factory assembled and pressure tested up to ten sections. For longer radiators additional blocks are supplied complete with nipples and joints for site assembling - refer Page 5 for sizes. Assembling tools are optionally available where additional blocks are supplied. For small orders (max. 10 radiators) warehouse assembled blocks up to 20 sections long for P200, P350, P500 and P650 models or 15 sections long for P800 models are available at extra cost.

Connections

All connection fittings, including joining nipples for site assembling of blocks, must be dry jointed using the joint rings supplied. Thread pastes or tapes with or without packing such as hemp must not be used. All machined faces and threads must be thoroughly cleaned before joining - refer page 6.

A set of connection fittings and joint rings is provided for each radiator. Each set comprises :

- 2 x R1¼ x R½ pipe connection bushes (or R1¼ x R¾ when requested)
- 1 x R1¼ plug (RH thread)
- 1 x R1¼ vent bush (LH thread) and R½ vent valve.

Radiators are normally installed with either BOE (bottom opposite end) or TBOE (top & bottom opposite end) connections.

For installations with BOE connections, a flow diverter should be fitted at the inlet connection for radiators up to 20 sections long. The flow diverter is attached to the inlet bush connection and is supplied as an accessory.

The vent valve should always be fitted at the outlet end of the radiator. If necessary, rotate the radiator to position the vent correctly.

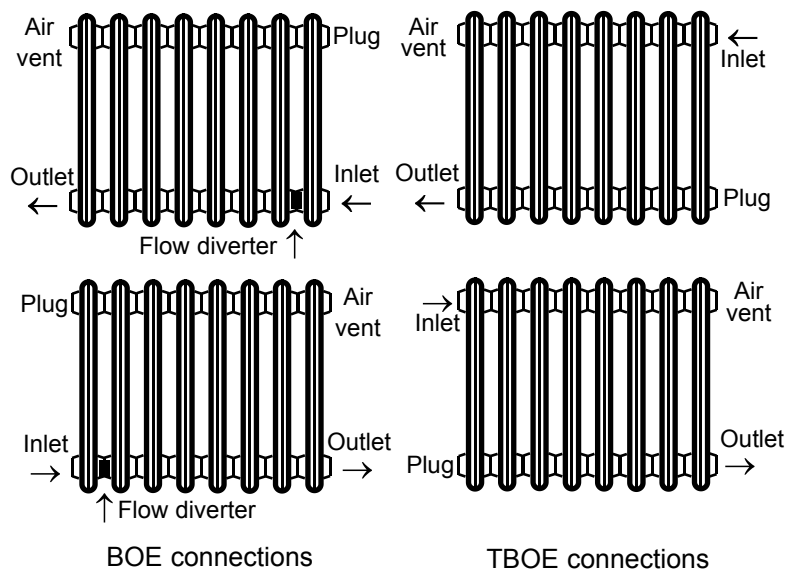

Boxing and enclosures

A full width sill above the radiator extending the depth of the radiator will reduce emission rates by approximately 4%.

Boxing of radiators or the use of decorative enclosures will reduce emission rates by upwards of 15%, according to the design of the boxing. Any restriction of the free flow of air over the radiator surface is detrimental to convected heat emission. Obscuring the front surface of the radiator eliminates the beneficial effect of radiated heat.

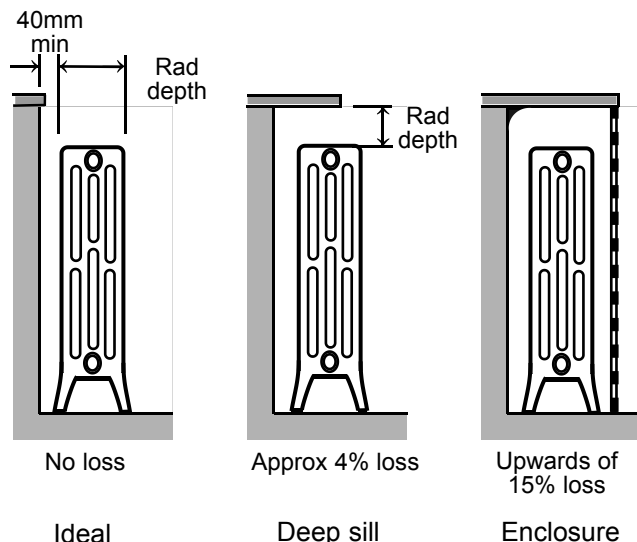

Fixing arrangements and block make-up

Always use Clyde radiator brackets, supports and stays. Clyde provide a pair of wall stays for each radiator which must be fitted. All screw fixes and wall plugs must be proprietary fittings selected to be suitable for the fabric of the wall to which the supports or stays are being fixed. Do not use fibre or

ceramic plug materials as these degrade in time and become unreliable. Advice on screw fixes and wall plugs is provided by specialist suppliers such as Fischer or Rawlplug. Pipework should never be used to provide support for the radiator.

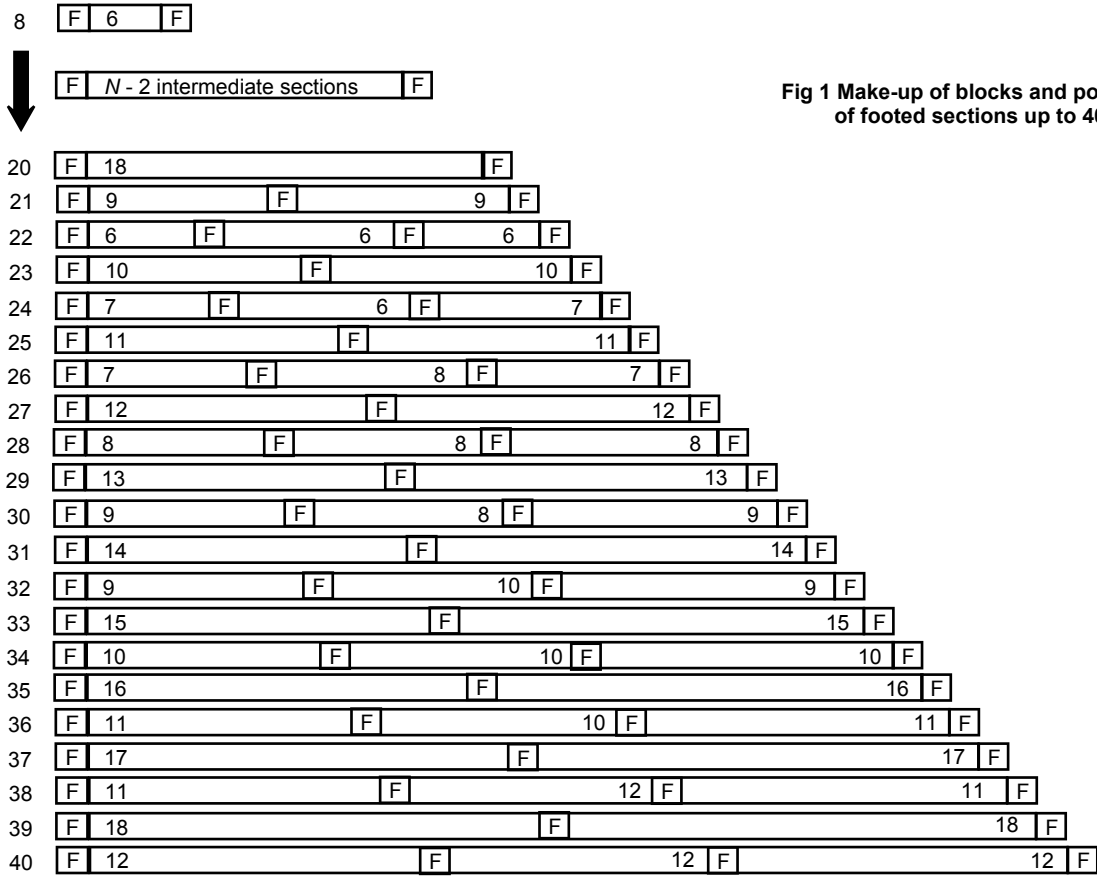
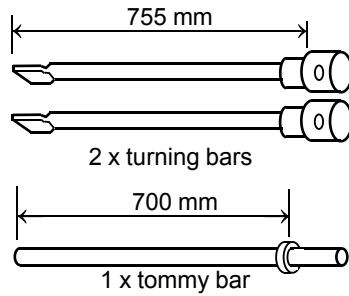

Fig 1 Make-up of blocks and positioning of footed sections up to 40 sections

Connections

Radiator blocks have Rp1¼ right hand threads at one end and Rp1¼ left hand threads at the other. Lay the blocks out so the right hand threads are aligned with left hand threads to suit the threaded nipples - refer diagram below. Before joining, inspect all blocks for primer paint runs and arrange these to be at the bottom of the radiator. Paint runs can usually be removed with a stiff wire brush. Match all blocks so that the assembled radiator is uniform along its entire length.

Assembling tool set



Block assembling

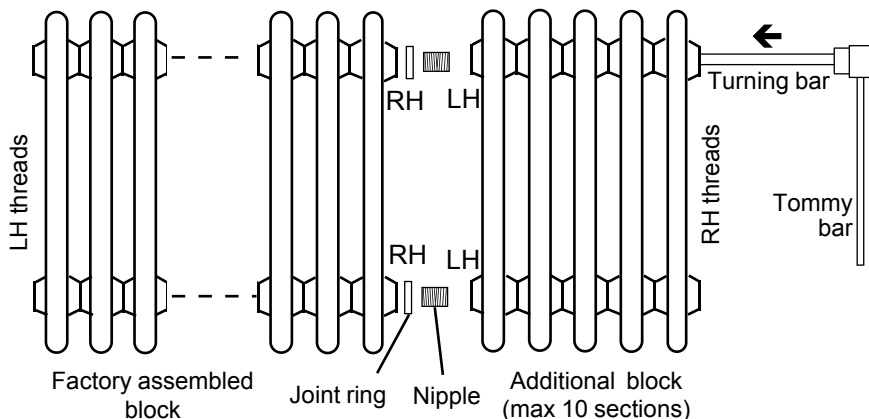

Carrying radiators

Cast iron radiators are heavy. Always provide sufficient manpower to make carrying safe. Incorrect handling of radiator blocks can cause water leaks from section joints. Lift the radiator blocks in the centre to bring them to the vertical position before lifting and carrying. Never carry radiators stretcher fashion.

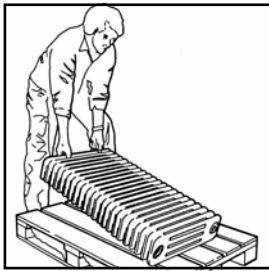

DO NOT !
Lift from one end

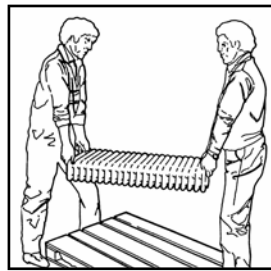

DO NOT !
Carry radiators flat

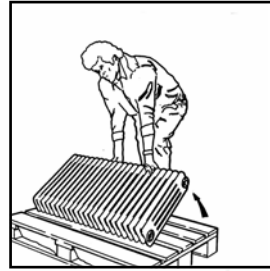

Always !
Lift in centre

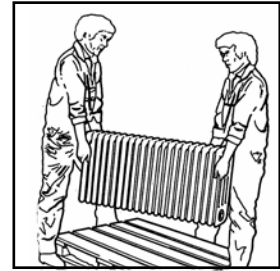

Always !
Keep sections vertical



Assembling

Sections are joined with dry fitted joint rings between the machined faces of each section. Bushes and plugs are dry sealed in the connections at each end of the radiator with a joint ring supplied as part of the bush or plug. Hemp, tape or sealing compounds must not be used.

- 1 Position the section block horizontally on two lengths of timber.
- 2 Ensure that the machined faces and threads of the section are perfectly clean.
- 3 Screw two nipples one full turn into each of the section tappings. Note that the nipples have left and right handed threads.
- 4 Place a joint ring (as supplied) on each nipple.
- 5 Clean the machined surfaces and threads of the adjoining block or section. Lay this block or section beside the first block ensuring that the threads mating to the nipples have the correct thread rotation.
- 6 Measure and mark off the length of the adjoining block or section on the nipple turning bars.
- 7 Insert the turning bars through the nippleways of the adjoining block or section to engage with the nipples.
- 8 Rotate both nipple turning bars equally to draw the blocks together keeping them parallel. If the blocks are not pulled together evenly, threads can be damaged and may give rise to leakage. Tighten the section nipples to a torque of 300 - 380 Nm (220 - 280 ft.lbs) - ie. the full weight of a 10-stone man bearing down on a 2ft long tommy bar.
- 9 Repeat operations 2 to 8 until the radiator is fully assembled.
- 10 If a flow diverter is required, this should be fitted at the inlet to the radiator block. Refer to the fitting instructions supplied with the diverter.
- 11 Fit bushes, blank plug and vent valve according to the connection plan required - refer page 4.

Choice of paint

Pembroke radiator blocks are supplied with a protective primer coating that will afford limited protection against the formation of rust provided that the blocks are correctly dry stored. Blocks will rust if they become wet.

THIS PROTECTIVE PRIMER COATING IS NOT INTENDED AS AN UNDERCOAT.

For a superior, long lasting paint finish we recommend that a protective coat of a zinc based rust inhibitor is applied. This must be compatible with the undercoat and finish coat selected for the radiator.

Radiators may be finished with most domestic paints that are formulated to withstand temperatures up to 100°C. Spray paints (air drying or oven cured) as used for car bodywork are also suitable. Paint supplier's recommendations regarding the use of an undercoat should be observed to ensure a true colour rendering.

Topcoats and undercoats **MUST NEVER** be WATER BASED or EMULSION type. Care must be taken in selecting undercoats as many modern formulations are water based although they are designed for use with oil based topcoats. A water based paint will always create rust pocks that will grow and become unsightly.

Painting

Paint may be applied by brush or spray and an undercoat should be applied, in accordance with the paint manufacturer's instructions. The quantity of paint required may be calculated from the coverage factor declared by the paint manufacturer and the surface area of the radiator sections - refer Technical Data, page 2.

Mount the radiators in their final positions and complete all pipe connections. Painting radiators 'in situ' against a wall is not recommended as the entire surface cannot be reached and there will be a high risk of rust formation on untreated surfaces.

When all installation work has been completed, disconnect the pipework and remove the radiators from the wall. Because the radiators are heavy and cumbersome to move, it is highly advisable to paint each radiator close to where it is being installed. Stand or lay the radiators on wood chocks. For safety, radiators must be supported whilst standing up, but it is necessary to turn them over to examine and treat all surfaces.

Using dry cloths, a wire brush and/or emery sheets, remove all dust and debris from the radiator surface. If any rust spots are found these must be removed and then treated with a chemical rust cleaner such as 'Jenolite'.

This publication is issued subject to alteration or withdrawal without notice. The illustrations and specifications are not binding in detail. All offers and sales are subject to the Company's current terms and conditions of sale, a copy of which is available on request.

Clyde Energy Solutions Ltd

Units 13 - 14 Charlwoods Rd
East Grinstead
West Sussex RH19 2HU
t : 01342 305550
f : 01342 305560
e : info@clyde4heat.co.uk
w : clyde4heat.co.uk

EDS 818/1
October 2010