

Natural gas
Propane Gas
Class D oil
Dual fuel

378 kW
to
930 kW

CKOM

Cast iron boiler



- **Seasonal efficiency of over 84% gives compliance with ADLB2 2010 for gas-fired boilers without the need for additional heating credits**
- **Compact heat exchanger gives small footprint relative to output**
- **Delivered in loose sections for easy site access**
- **Wide range of 2-stage gas and oil, dual-fuel and modulating gas burners available**

Contents	Page
General information	2
Dimensions & data	3 & 4
Installation requirements	5 - 7
Boiler control & wiring	7 & 8

General information

Description

CKOM cast iron sectional boilers are designed for use in either open vented or pressurised heating systems up to 6 bar working pressure with gas, oil or dual fuel burners. There are eleven models in the range 378 kW to 930 kW. The boiler has a pressurised combustion chamber and burners offered by Clyde are all capable of overcoming the boiler resistance without the assistance of the chimney.

These are 3-pass boilers and comply with the efficiency requirements of ADL2: 2010 of The Building Regulations.

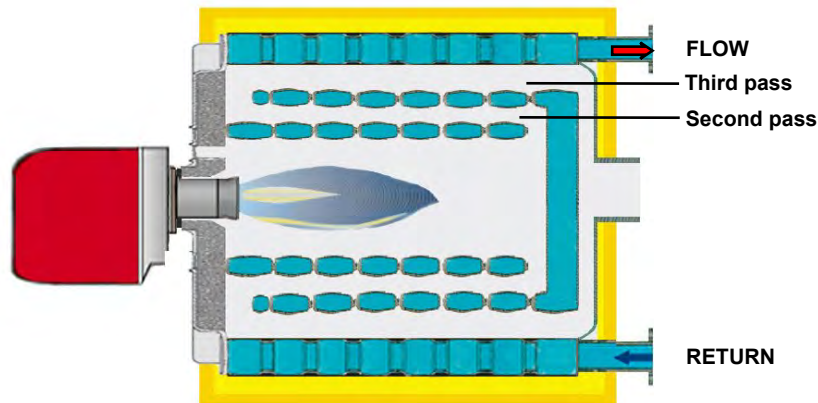

Fig 1 3-pass operation of boiler

Application

CKOM boilers are made from Grade GG20 cast iron and conform with the requirements of EN 303. The boilers are suitable for use in LTHW heating systems with a maximum operating pressure of 6 bar and maximum temperature of 90°C.

CKOM boilers may be fired by Natural gas, LPG, Class D or Class C oil with modulating or 2-stage control.

The boiler is suitable for use in either open vented or pressurised heating systems. It is not suitable for use as a direct water heater. Where potable water is required, a matching calorifier or plate heat exchanger must be provided in the system.

Statutory requirements

CKOM boilers are CE marked and must be fired by a compatible burner certified to EN267 (oil firing) or EN676 (gas firing).

The installation, assembling and commissioning of the boiler must be carried out by a qualified engineer in accordance with the instructions provided.

Gas supplies and gas burners must be installed and commissioned by a qualified person, eg. a Gas Safe registered engineer.

Materials & boiler assembling

The boiler is supplied as loose cast iron sections for assembly on site. Each section is tested hydraulically for soundness in accordance with EN303. The assembled boiler should also be hydraulically tested on site in accordance with this standard and a test certificate issued. Insulation, steel jacket, boiler control panel and burner are packed separately for fitting on site.

Site assembling should only be undertaken by Clyde or their authorised engineer. All insulating and refractory materials are included, with ceramic sealing ropes for all access doors.

Handling

Offloading, dry storing and placing of equipment in the boiler room is the responsibility of the installer.

Equipment must be dry stored and protected from frost. Cartons must not be crushed or otherwise damaged.

Commissioning

Clyde undertake commissioning of boilers. Commissioning

charges do not include servicing during the guarantee period. This may be carried out under service contract or to specific order.

Boiler log book

A boiler log book that provides a permanent record of commissioning and servicing data and measurements is supplied with every boiler. It should be kept safe and updated whenever routine or emergency work is performed on the boiler.

Guarantee

Subject to correct handling, installation and operation, all equipment is guaranteed for twelve months from the date of despatch. Boiler sections are guaranteed for a period of five years from the date of despatch.

The guarantee is not valid if the boiler is subjected to thermal stress, becomes blocked with debris and/or carbonate deposits from the system water and/or there is no documented evidence of commissioning by a competent engineer.

Dimensions and technical data

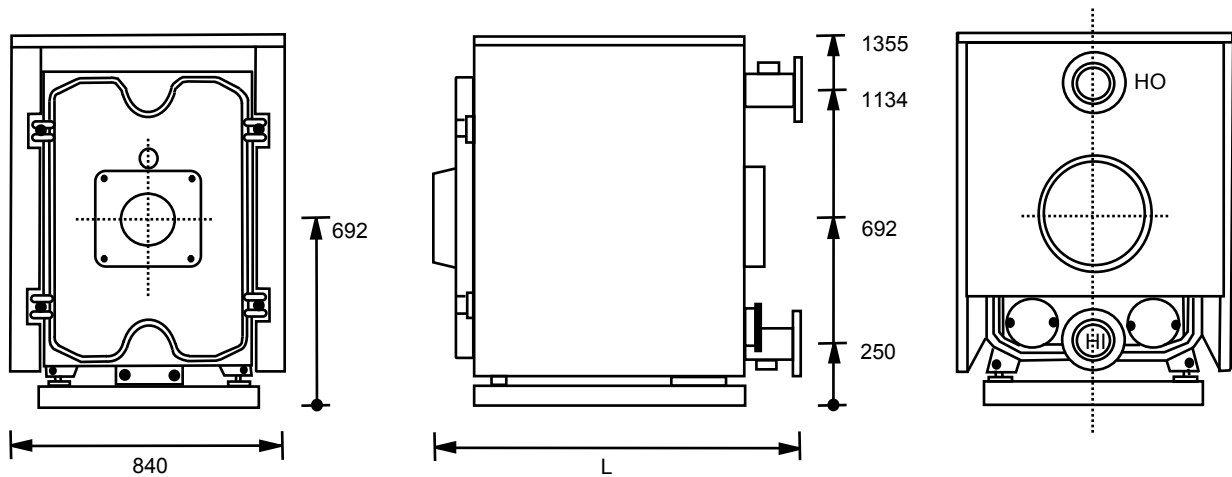

Dimensions

Boiler model		CKOM-06	CKOM-07	CKOM-08	CKOM-09	CKOM-10	CKOM-11
Output	kW	378	448	506	564	610	663
No. sections		6	7	8	9	10	11
Overall length	L mm	1300	1460	1620	1780	1940	2100
Combustion chamber length	mm	910	1070	1230	1390	1550	1710
Combustion chamber diameter	mm	501					
Boiler door thickness	mm	145					
Boiler flow connection	HO	DN100					
Boiler return connection	HI	DN100					
Flue spigot diameter	mm	350					

Technical data

Nominal heat output (full load) ncv	kW	377.9	447.7	505.8	564	610	662.8
Nominal heat input (full load) ncv	kW	410.1	486.9	550.8	614.8	665.3	719.8
Efficiency at 100% load (ncv)	%	92.1	91.9	91.8	91.7	91.7	92.1
Efficiency at 30% load (ncv)	%	95.2	95	94.9	94.8	94.7	95.1
Boiler seasonal efficiency(1)	%	85.2	85.1	85	84.9	84.8	85.2
Natural gas consumption (gcv)	m³/h	42.5	50.4	57.1	63.7	68.9	74.6
Oil consumption class D (ncv)	kg/h	35.1	41.7	47.1	52.6	56.9	61.6
Dry weight (excludes burner)	kg	1090	1230	1370	1510	1650	1790
Water volume	litres	150	174	199	223	248	272
Flue gas mass flow @3% oxygen	m³/h	42.2	50.1	56.7	63.3	68.5	74.1
Chimney draught	Pa	0					
Gas side resistance	mbar	2.2	2.4	2.75	3.1	3.35	3.7
Flue gas temperature rise @3% oxygen	Nat gas (2)	168	167	165	164	164	162
	Class D oil	189	187	184	182	181	181
Maximum working temperature	°C	90					
Maximum hydraulic working pressure	bar	6					
CE-Registration number		CE 1015BR0262					

Water flow rates and hydraulic resistances

Water flow rate at 11°C temp. rise	l/s	8.2	9.7	11	12.3	13.3	14.4
Hydraulic resistance at 11°C temp. rise	kPa	17.4	18.2	20.9	24.1	26.6	31.4
Water flow rate at 20°C temp. rise	l/s	4.5	5.3	6	6.7	7.3	7.9
Hydraulic resistance at 20°C temp. rise	kPa	5.4	8	9.2	10.5	11.2	12.1
Water flow rate at 30°C temp. rise	l/s	3	3.6	4	4.5	4.8	5.3
Hydraulic resistance at 30°C temp. rise	kPa	2.1	3.5	3.7	4.8	6.2	7.2

Notes: (1) Calculated from the non-domestic heating and cooling compliance guide for conformance with ADL2A and

ADL2B 2010 using the formula $n_{\text{seasonal}} = 0.81n_{30\%} + 0.19n_{100\%}$

(2) BS 7190:1989

Dimensions and technical data

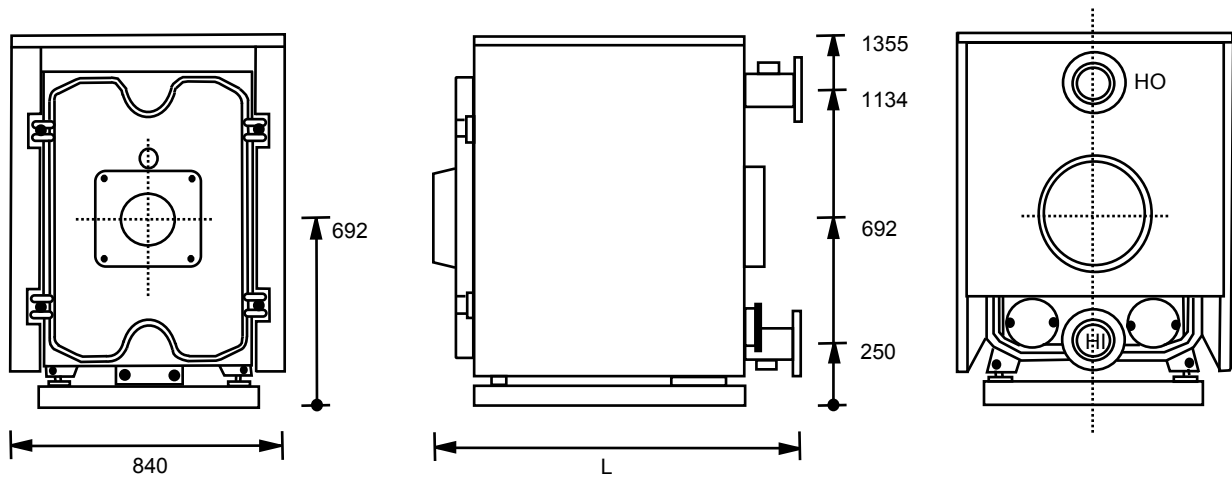

Dimensions

Boiler model		CKOM-12	CKOM-13	CKOM-14	CKOM-15	CKOM-16
Output	kW	715	773	831	878	930
No. sections		12	13	14	15	16
Overall length	L mm	2260	2420	2580	2740	2900
Combustion chamber length	mm	1870	2030	2190	2350	2510
Combustion chamber diameter	mm	501				
Boiler door thickness	mm	145				
Boiler flow connection	HO	DN100				
Boiler return connection	HI	DN100				
Flue spigot diameter	mm	350				

Technical data

Nominal heat output (full load) ncv	kW	715.1	773.3	831.4	877.9	930.2	
Nominal heat input (full load) ncv	kW	777.3	839.1	899.9	955.6	1013	
Efficiency at 100% load (ncv)	%	92	92.2	92.4	91.9	91.8	
Efficiency at 30% load (ncv)	%	95	95.2	95.4	94.9	94.8	
Boiler seasonal efficiency(1)	%	85.1	85.2	85.4	85	84.9	
Natural gas consumption (gcv)	m³/h	80.5	86.9	93.2	99	105	
Oil consumption class D (ncv)	kg/h	66.5	71.8	77	81.8	86.7	
Dry weight (excludes burner)	kg	1940	2080	2220	2360	2500	
Water volume	litres	297	321	346	370	395	
Flue gas mass flow @3% oxygen	m³/h	80.1	86.4	92.7	98.4	104.3	
Chimney draught	Pa	0					
Gas side resistance	mbar	4.05	4.35	4.75	4.95	5.5	
Flue gas temperature rise @3% oxygen	Nat gas (2)	°C	161	161	160	159	157
	Class D oil	°C	180	180	178	176	173
Maximum working temperature	°C	90					
Maximum hydraulic working pressure	bar	6					
CE-Registration number		CE 1015BR0262					

Water flow rates and hydraulic resistances

Water flow rate at 11°C temp. rise	l/s	15.5	16.7	18	19	20.1
Hydraulic resistance at 11°C temp. rise	kPa	34.7	40.5	44.4	49.1	52.9
Water flow rate at 20°C temp. rise	l/s	8.5	9.2	9.9	10.5	11.1
Hydraulic resistance at 20°C temp. rise	kPa	12.8	14.3	15.4	16.1	17.3
Water flow rate at 30°C temp. rise	l/s	5.7	6.1	6.6	7	7.4
Hydraulic resistance at 30°C temp. rise	kPa	8.1	8.3	9	9.8	10.3

Notes: (1) Calculated from the non-domestic heating and cooling compliance guide for conformance with ADL2A and

ADL2B 2010 using the formula $n_{\text{seasonal}} = 0.81n_{30\%} + 0.19n_{100\%}$

(2) BS 7190:1989

Installation requirements

Boiler location (Refer Figs 2 & 3)

The location chosen for the boiler(s) must be frost free, provide for a satisfactory flue system and an adequate air supply for combustion and ventilation. Adequate access is necessary for boiler and burner servicing.

Boilers must not be installed in areas where flammable vapours are likely to be present. To avoid damage to the boilers, contamination of the combustion air by high levels of dust or halogenated hydrocarbons (eg. Solvents, spray can propellants, cleaning agents, adhesives, etc) must be avoided.

Boilers should be installed on a plinth which is at least 50mm high and is smooth and level (NB : for some burners with acoustic shrouds the plinth may need to be higher - refer Clyde Sales Office).

An uneven plinth can inhibit freedom for expansion and contraction of the boiler during operation.

Burners

Boilers can be supplied with one or two stage Natural gas, LPG, Class D or Class C oil burners. A choice of burner makes is available.

Fuel specification

Natural gas (GCV 38.76 MJ/m³) with a minimum gas inlet pressure according to the burner model specified.

BS2869 Class D oil (35 sec). Advice should be sought from the oil supplier regarding the storage of Class D oil.

Fuel supply pipework

Install gas or oil supply pipe(s) and service valve(s) so as to allow free access to the boiler and full opening of the furnace door without removing the burner from the boiler door (see below).

Commissioning of the gas supply pipework and components must be carried out by a qualified person, eg. a Gas Safe registered engineer. The gas meter and supply must be sited in accordance with the requirements of BS6400.

Plant room layout (Refer Fig 2)

When planning the layout of the boiler room, allowance must be made for opening the boiler door, boiler assembling, boiler cleaning and maintenance. The boiler door may be hinged from the right (as illustrated) or the left. A ceiling height of at least 2.3m is recommended. Wall clearances are:

- W1 - at least 700mm.
- W2 - burner length A + 100mm.
- W3 - 1000mm (in front of boiler for cleaning).
- W4 - 500mm minimum (behind boiler for cleaning).

Plinth dimensions (Refer Fig 3)

Plinth height - at least 50mm, smooth and level.

Boiler	L1 mm
CKOM -06	1300
CKOM-07	1460
CKOM-08	1620
CKOM-09	1780
CKOM-10	1940
CKOM-11	2100
CKOM-12	2260
CKOM-13	2420
CKOM-14	2580
CKOM-15	2720
CKOM-16	2900

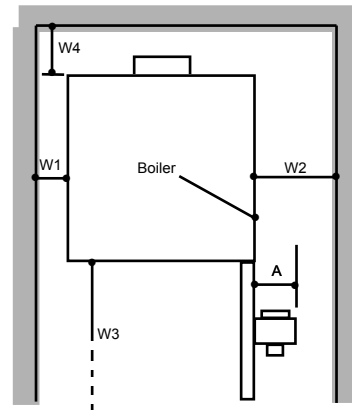

Fig 2 - Wall clearances

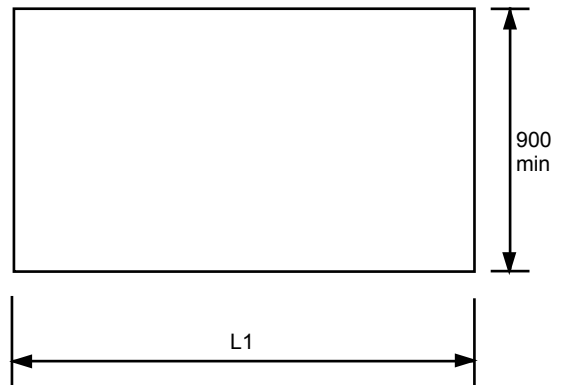

Fig 3 - Plinth dimensions

Installation requirements

Air supply

Air for ventilation and combustion must be provided for gas fired boilers in accordance with either BS 6644:2005 or IGEM/UP/10. Air supply for oil fired boilers must conform to BS 5410 : Part 2.

Chimney design

The CKOM boiler is designed to operate with a pressurised combustion chamber and the chimney is not required to assist the burner in overcoming the boiler resistance. The chimney must cater for the total internal resistance of the flue system from each boiler outlet and not impose an additional load on the burner.

Water circulation (Refer Fig 4)

The flow water temperature from the boiler must reach 60°C (gas firing) or 50°C (oil firing) within 10 minutes of the boiler being brought into operation. Thereafter, water circulation should be maintained through the boiler such that the boiler flow water temperature is always above 60°C (gas firing) or 50°C (oil firing). A pump overrun facility is necessary to ensure that water circulation is maintained for at least three minutes after the boiler is switched off.

There are several ways of providing boiler protection, eg shunt pumps, primary loops, etc. A typical boiler pump and 3-port valve arrangement is shown in Fig 4a and b.

For multi-boiler systems a 'reverse return' pipework configuration is required to ensure equal distribution of water flow through the boilers.

Water treatment

Whenever a new boiler is connected to an existing system, the pipework must be thoroughly cleaned and flushed. Clyde recommend that a permanent means of filtration be fitted into the return pipework, such as a sludge trap, hydrocyclone or full flow duplex filters. The boiler guarantee will be invalid if waterways are blocked by debris or carbonate deposits. Long term water treatment is essential to the economic operation and life of both new and refurbished heating systems.

For full information on cleaning, flushing and protecting hot water systems, refer to BSRIA Application Guide AG 1/2001.

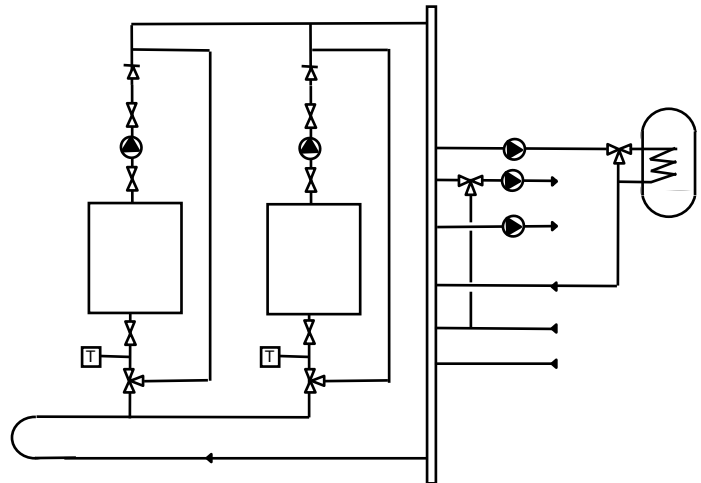

Fig 4a Multiple boilers with individual pumps

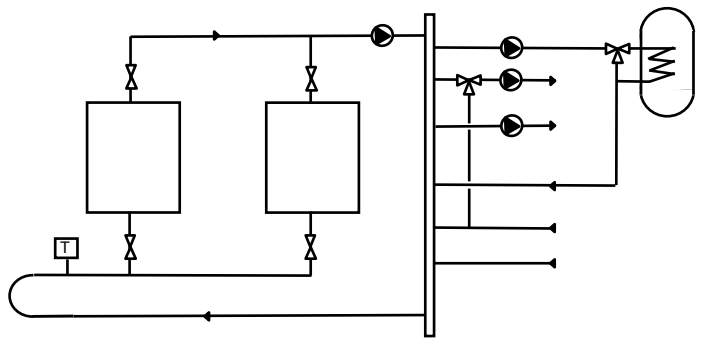

Fig 4b Alternative arrangement for boiler protection with a primary loop

Electrical supply (Refer Fig 5)

A 400V 3PH supply is required for the standard burners offered, and the connection details are shown opposite. The boiler control panel requires an additional 230V 1PH supply.

The electricity supplies to the burner and boiler control panel must be wired in accordance with IEE Regulations. A separate supply and isolating switch is required for each boiler in the plant room.

All isolating switches and fuses must be provided by the installer. Burner start/run currents for fuse specification are available on request. Burner wiring diagrams and technical data are also available on request.

All connections between the boiler control panel and the burner are made through harnesses with matching plugs and sockets, supplied as standard.

Note: Fig 5 is only diagrammatic. Double pole switches with the required minimum separation must always be used.

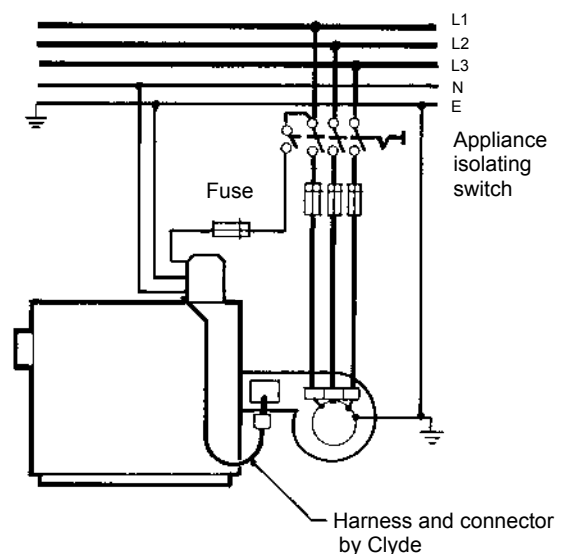

Fig 5 - Electricity supply

Installation requirements

Flow and return water connections

The cast iron connection pieces are shown in Figs 6a and 6b below. The return connection incorporates a water turbulator that eliminates the need for a sparge pipe in the boiler return. There is an R1¼ BSP tapping in each connection for use as a boiler drain point and can also be used for shunt pump connection (if required).

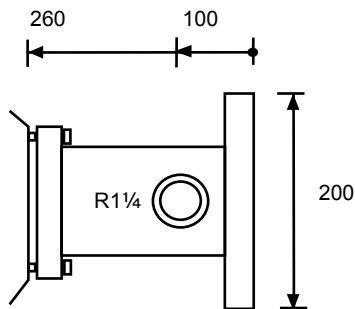

Fig 6a Flow water connection

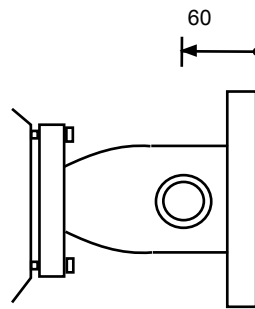

Fig 6b Return water connection

Boiler control panel and wiring

Control panel CKCR2 provides 2-stage burner control for high/low operation whilst panel CKCR1 provides 1-stage burner control for modulating burner operation. Thermostat TR is a 1-stage item with CKCR1 and a dual thermostat (1 and 2 stage) with CKCR2.

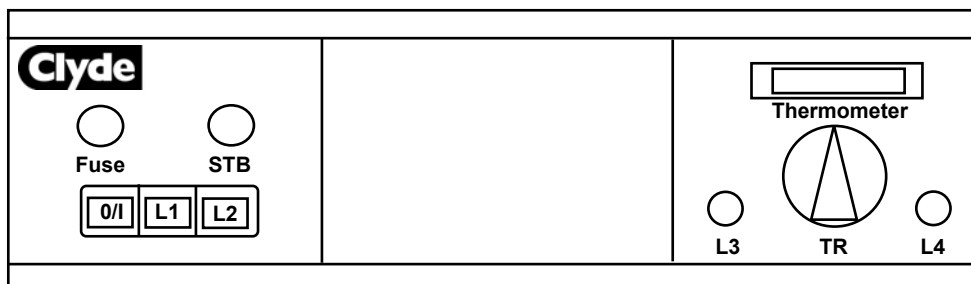

Fig 7 Boiler control panel

Boiler control panel and wiring

Key to figs 7 and 8

- EC1 Energy Control 1
- L1 On/off indicator lamp
- L2 Boiler high limit lock-out lamp (lamp is illuminated when running and goes out in lock-out conditions)
- L3 Stage 1 run lamp
- L4 Stage 2 run lamp
- STB High limit thermostat (factory set)
- TR Boiler thermostat (1-stage for CKCR1 or dual operation [TR and TR2] for CKCR2)

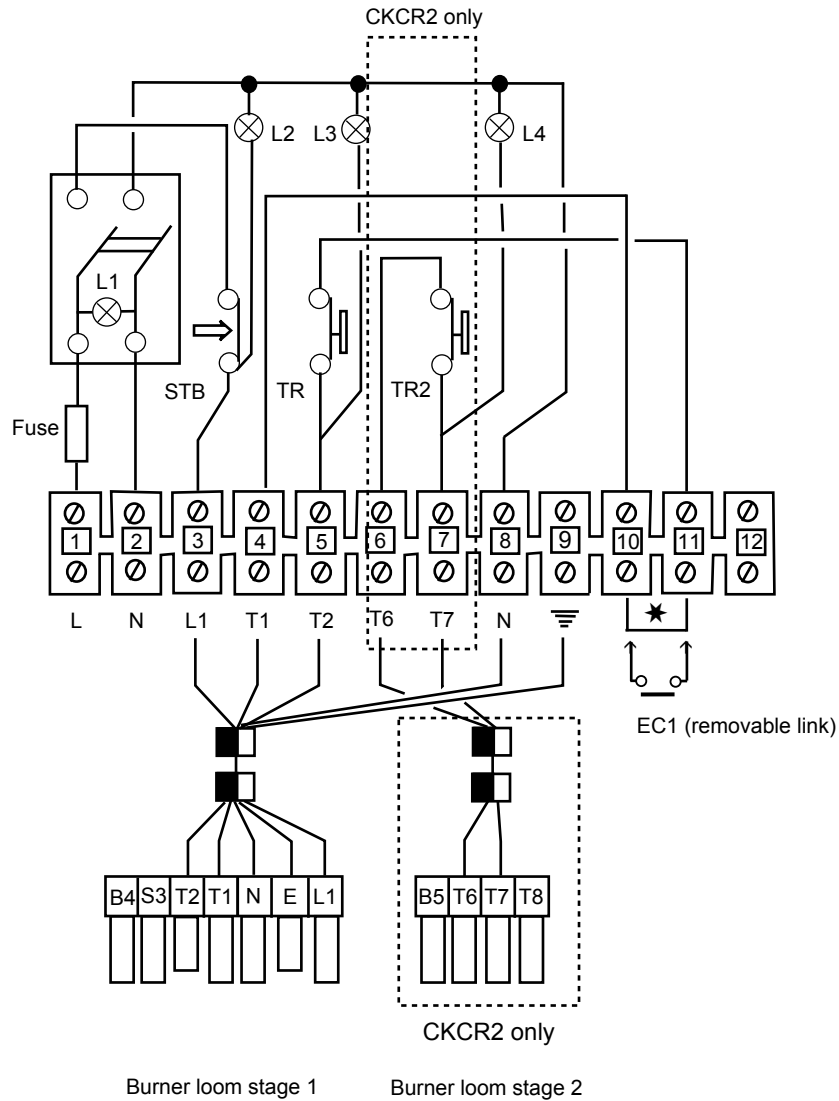

Fig 8 Boiler control panel wiring

This publication is issued subject to alteration or withdrawal without notice. The illustrations and specifications are not binding in detail. All offers and sales are subject to the Company's current terms and conditions of sale, a copy of which is available on request.

Clyde Energy Solutions Ltd

Units 13 - 14 Charlwoods Rd
 East Grinstead
 West Sussex RH19 2HU
 t : 01342 305550
 f : 01342 305560
 e : info@clyde4heat.co.uk
 w : clyde4heat.co.uk

EDS 805/3
 November 2011