

Vertical, steel,
enamel lined
storage vessels
for potable hot
water

150 to 1000
litres
Storage capacity

Sanical calorifiers

Vertical calorifiers



Contents	Page
General information	2
Schematic pipework	3
Dimensions	4
Technical Data	5
Control panel	6

General information

Description

Clyde Sanical calorifiers are manufactured from heavy gauge steel with a smooth, durable and hygienic double enamel coating to DIN 4753. Further protection against electrolytic corrosion is provided by a magnesium sacrificial anode. They are suitable for a maximum working pressure of 10 bar on the secondary side and 6 bar on the primary side. The Sanical range have a large water capacity primary coil to maximise heat transfer. Models 150 to 600 have 50mm hard polyurethane (PU) insulation and models 800 and 1000 have 100mm soft PU insulation.

System Design

Publications relating to the storage of potable hot water and the control of legionella bacteria in water systems are available from the Health and Safety Executive (eg Approved Code of Practice and Guidance L8 from HSE Books) and the Chartered Institution of Building Services Engineers (eg TM13:2000 from CIBSE). These publications give guidance on system design including minimum stored water temperatures and the prevention of temperature stratification in calorifiers and storage tanks.

Application

The Clyde range of calorifiers have indirect primary heating coils and are designed for use as hot water storage vessels in open vented or direct feed potable water supplies with a conductivity greater than than 100 $\mu\text{S}/\text{cm}$ (micro-siemens / cm). If used with water supplies having a conductivity less than 100 $\mu\text{S}/\text{cm}$, the protection afforded by the internal anode is progressively inhibited and the guarantee provided by Clyde is reduced - refer 'Guarantee' below. They are not suitable for use in saline, de-ionised or chemically treated water systems.

Calorifiers must be installed so as to comply with the requirements of the Water Byelaws Regulations and must be installed by a competent person. For use as an unvented water heater in a domestic situation, the installation must conform with G3 building regulations.

Location

The location of Clyde calorifiers must provide adequate space for pipework connections and jacket fitting where applicable. The location chosen must permit servicing and maintenance of the calorifier, anode and auxiliary equipment - refer to page 4 for recommended clearances. A specially built plinth is not necessary but calorifiers should be installed on a level surface that is capable of supporting the weight of the filled calorifier and auxiliary equipment.

Storage & handling

To avoid damage to the magnesium anode and enamelled lining, vessels must always be handled and stored vertically in a dry, frost-free environment.

Sanical calorifier controller

The calorifier control panel includes a thermostat, temperature gauge and on/off switch. Full details are given on page 6.

Primary Water Circulation

To achieve the rating and flow rates it is important that the primary pump is sized in accordance with the data given - refer Technical data, page 5.

Secondary Water Circulation

A secondary water return connection is provided to allow recirculation back to the calorifier and ensure that hot water is constantly available at the service outlets - see the schematic pipework arrangement on page 3.

Maintenance and protective anode

Filled and unheated calorifier vessels must never be allowed to freeze. After installation the secondary water storage must be filled before heated water is permitted to flow through the primary coil.

The internal surfaces of the vessel must be inspected periodically and kept free of hard water calcium deposits. Magnesium anodes should be inspected every two years and replaced if more than 50% has been consumed.

Guarantee

Sanical calorifiers are designed for use with potable water supplies only. The guarantee is invalid if the calorifier is used on other types of water supply, eg, saline, de-ionised, etc.

Subject to correct handling, installation, use and maintenance, and providing that the conductivity of the water supply is greater than 100 $\mu\text{S}/\text{cm}$, Sanical calorifier vessels are guaranteed for 2 years from the date of delivery. If the conductivity of the water supply is less than 100 $\mu\text{S}/\text{cm}$, Sanical calorifier vessels are guaranteed for 1 year. Control equipment and sacrificial anodes are guaranteed for 1 year.

The guarantee will become invalid if :

- The vessel becomes blocked with carbonate deposits.
- A magnesium anode shows signs of excessive wear.

Electric immersion heaters

Optional electric immersion heaters are available - refer to Clyde for details

Schematic pipework arrangement

The pipework schematic of Fig 1 illustrates an unvented hot water storage system that generally complies with the Water Supply (Water Fittings) Regulations 1999 and Part G of The Building Regulations. The Sanical calorifier controller has an in-built control thermostat. Maximum working pressures are 6 bar primary and 10 bar secondary. Alternatively, an open-vented system may be used.

Although fig 1 shows the secondary circulation (bronze) pump on the return to the calorifier, it is not unknown for this pump to be fitted in a small loop on the secondary water flow, where it can directly assist the flow without restricting the bore of the pipework.

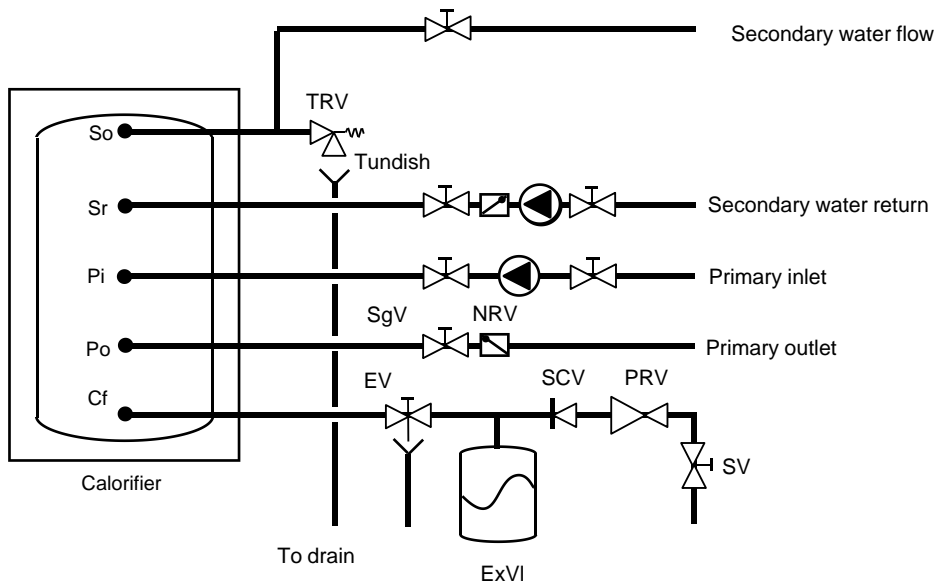

Fig 1 Pipework schematic for an unvented hot water storage system

Key to fig 1

SV	Stop cock with drain tap
PRV	Pressure reducing valve (if required)
SCV	Single check valve
ExVI	Expansion vessel
EV	Expansion valve with discharge to tundish
NRV	Non-return valve
SgV	Service valve
TRV	Temperature relief valve or Temperature and Pressure relief valve with discharge to tundish

Cf	Cold feed
Pi	Heating primary inlet
Po	Heating primary outlet
So	Secondary outlet
Sr	Secondary return

Dimensions

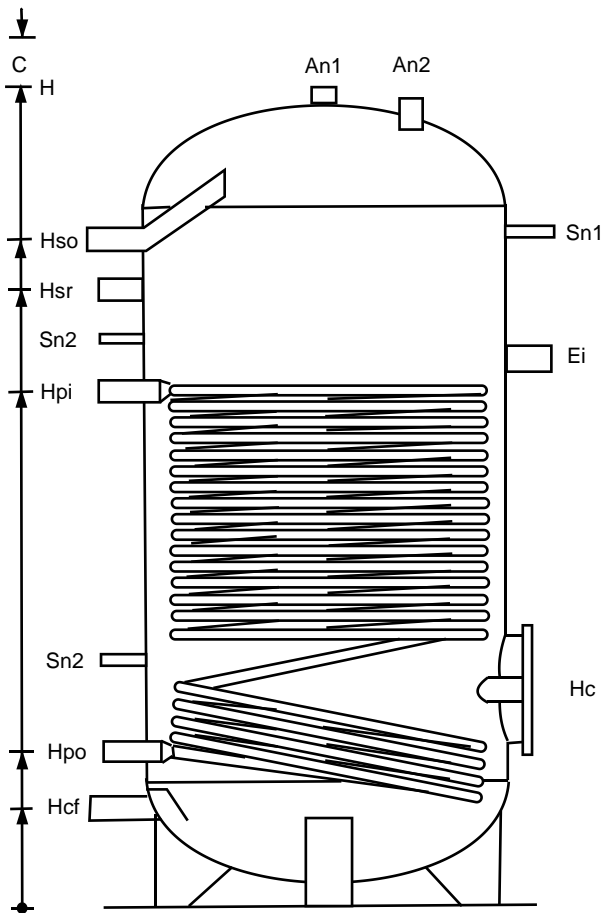

Fig 2a Section of Sanical models 150 to 800

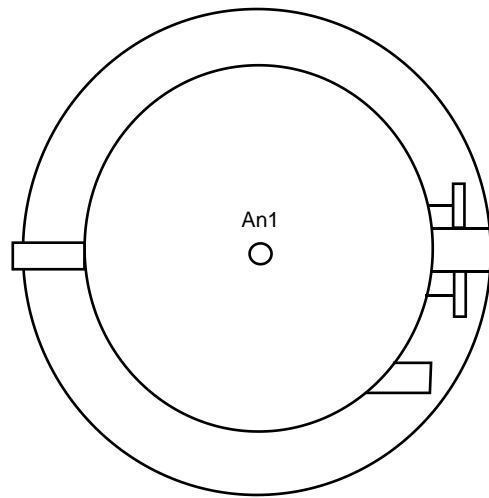

Fig 2b Plan of Sanical models 800 + 1000

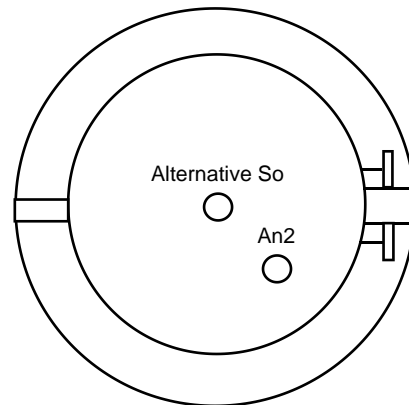

Fig 2c Plan of Sanical models 150 to 600

Connections

- So Secondary outlet
- Sr Secondary return
- Cf Cold feed
- Pi Primary inlet
- Po Primary outlet
- An1 Anode position models 800 +1000 (Rp1½)
- An2 Anode position models 150 to 600 (Rp1¼)
- Hc Handhole cover
- Ei Electric immersion heater (optional)
- Sn1 Sensor pocket for thermometer (Rp½)
- Sn2 Sensor pocket for thermostat (Rp½)

Recommended minimum clearances

For pipe connections	At rear	500mm
For access (reversible)	One side	500mm
	Other side	100mm
For access & cleaning	At front	600mm

Technical data

Calorifier model		150	200	300	400	500	600	800	1000
Vessel capacity	litres	168	212	291	423	500	589	765	888
Coil capacity	litres	6.3	9.5	11.4	12	14	15.7	16.6	19.2
Dry weight	kg	70	90	115	140	155	190	215	245
Max primary working pressure	bar	6							
Max secondary working pressure	bar	10							
Max. allowable temperature	°C	95							

Overall height	H mm	990	1215	1615	1460	1690	1960	1780	2030
Clearance above jacket	C mm								
Vessel diameter	mm	500	500	500	650	650	650	790	790
Overall jacket diameter	mm	600	600	600	750	750	750	990	990
Handhole diameter	Hc mm	180/120							
Primary inlet height	Hpi mm	620	750	890	795	880	985	1035	1235
Primary outlet height	Hpo mm	300	290	290	345	345	345	345	350
Cold feed height	Hcf mm	220	220	220	265	265	265	210	210
Secondary outlet height	Hso mm	765	975	1390	1185	1415	1685	1435	1700
Secondary return height	Hsr mm	495	635	1165	960	1170	1340	1145	1395
Secondary outlet	So	Rp1	Rp1	Rp1	Rp1	Rp1	Rp1	Rp1¼	Rp1¼
Secondary return	Sr	Rp½	Rp½	Rp½	Rp½	Rp½	Rp½	Rp1	Rp1
Primary inlet	Pi	Rp1	Rp1	Rp1	Rp1	Rp1	Rp1	Rp1¼	Rp1¼
Primary outlet	Po	Rp1	Rp1	Rp1	Rp1	Rp1	Rp1	Rp1¼	Rp1¼
Cold feed	Cf	Rp1	Rp1	Rp1	Rp1	Rp1	Rp1	Rp1¼	Rp1¼

Measured standby losses	kWh/24h	0.94	1.19	1.5	1.8	2.15	2.53	1.32	1.45
-------------------------	---------	------	------	-----	-----	------	------	------	------

Sanical duties at LTHW with secondary water at 60°C, primary water inlet at 80°C and cold feed at 10°C

Coil heating surface	m ²	1.0	1.5	1.8	1.9	2.2	2.5	2.7	3.5
Continuous rating	kW	24	36	44	46	55	63	68	88
Primary water flow rate	litres/s	0.28	0.44	0.53	0.56	0.67	0.75	0.81	1.06
Primary coil resistance	mbar	12	40	70	80	131	192	240	518
Secondary water flow rate	litre/h	412	618	755	789	944	1081	1167	1510
Recovery time	mins	35	29	33	46	45	47	56	57

Calorifier control panel

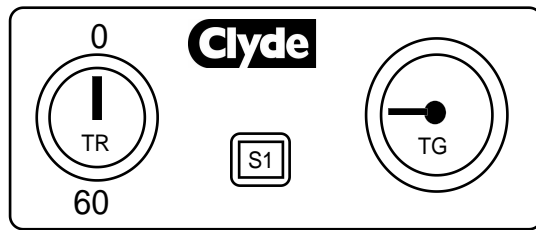
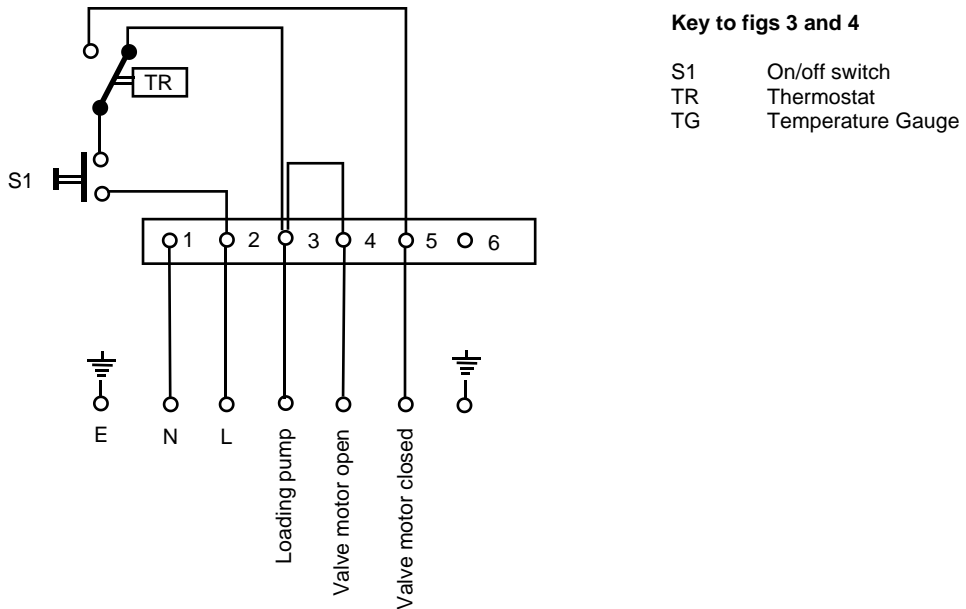

Fig 3 Calorifier control panel



Key to figs 3 and 4

- S1 On/off switch
- TR Thermostat
- TG Temperature Gauge

Fig 4 Wiring diagram for control panel

Sanical control panel

The Sanical calorifier control panel (see figs 3 and 4) incorporates a control thermostat, adjustable from 20 to 80°C. The thermostat controls the operation of a DHW loading pump or motorised valve.

Electric immersion heaters

An optional immersion heater is available, using an Rp 1½ connection. Please contact Clyde for details.

Clyde ENERGY SOLUTIONS

Clyde BOILERS

Clyde RADIATORS

Clyde HOT WATER SYSTEMS

Clyde SUSTAINABLE ENERGY

Clyde TECHNICAL SERVICES

Clyde CONSULTING

This publication is issued subject to alteration or withdrawal without notice. The illustrations and specifications are not binding in detail. All offers and sales are subject to the Company's current terms and conditions of sale, a copy of which is available on request.

Clyde Energy Solutions Ltd

Unit 10 Lion Park Avenue
Chessington
Surrey KT9 1ST

t : 020 8391 2020
f : 020 8397 4598
e : info@clyde-nrg.com
w : www.clyde-nrg.com



EDS 808/1
August 2008