

Natural gas  
Propane Gas

100 kW  
to  
900 kW

## *Unical Modulex*

Modular condensing gas boiler



- **Modular boiler with multiple burner units** to maximise flexibility and reliability
- **Turn-down ratios of up to 40:1** to match boiler output to heating load
- **Manual switch** allows boiler to run at 50% of nominal output in the event of boiler controls failure, ensuring security of heat generation
- **Seasonal efficiency of up to 97.1%** gives compliance with ADL2A and ADL2B of Part L 2006

Contents	Page
General information	2 & 3
Dimensions	4 - 6
Technical Data	4 - 6
Installation requirements	7 & 8
Boiler wiring	9
Hydraulic system design	10



## General information

---

### Operating principles

Modulex is a cast aluminium condensing boiler, with each section a self-contained heat generating module. Each module has a down-firing pre-mix gas burner with its own control and safety (limit) thermostats. The in-built *BCM (Boiler Cascade Manager)* will modulate the boiler on a cascade down to a minimum output of 12 kW for models 100 to 340 and 22 kW for models 440 to 900 - the minimum output of a single module. If any of the modules fail, the others will continue to operate. Multiple boilers can be cascaded by an external BCM or BMS. An *E8 Regulator* is mounted on each boiler to give local control of parameters and settings and control external pumps, sensors and valves. In the event of failure of the E8 Regulator, a rocker switch on the BCM will run the boiler at 50% output until a service engineer can attend.

Pre-mix burners use an air intake fan coupled to a venturi to control the volume of gas being entrained. The modulating control sets the speed of the fan, which accurately governs the volume of gas admitted through the gas valve. This ensures an optimum mixture of gas and air at any output rating, together with thorough mixing before ignition. Consequently, thermal efficiencies of up to 109% net are achieved.

Each module is a counter flow heat exchanger, to maximise heat transfer. Hot exhaust gases travel downwards under positive pressure of the air intake fan. The number of conical heat transfer pins increases towards the flue outlet at the bottom, maintaining an even heat transfer rate as the exhaust gases cool. The system water travels upwards through the modules to create the counter flow.

The modules are hydraulically connected in a reverse-return arrangement. Models 100 to 340 have water and gas connections handed on the right as standard, but can be changed on site to the left. The connections are handed on the left for models 440 to 900. A choice of flue connection positions are available - see pages 4 to 6.

The modules are cast from an aluminium / magnesium / silicon alloy that is light, strong and resistant to acid corrosion.



Fig 1 Diagram of operating principles

#### Key to Fig 1

- 1 Pre-mix gas burner
- 2 Ignition / ionisation probe assembly
- 3 Single module
- 4 Heat transfer pins
- 5 Module waterways
- 6 E8 Regulator

## General information

### Application

Modulex boilers are manufactured and tested in accordance with the Gas Appliances Directive 90/396/EEC, the Boiler Efficiency Directive 92/42/EEC, the EMC Directive 89/336/EEC, the LVD 73/23/EEC and the Machinery Directive 89/392/EEC and CE marked accordingly. They are suitable for use in LTHW heating systems with a maximum operating pressure of 6.0 bar and a maximum working temperature of 90°C (see Technical data on pages 4 to 6).

Modulex boilers are suitable for use with Natural gas (G20) or Propane (G31).

The boiler is suitable for use in pressurised (sealed) or open vented heating systems with a minimum static head of 0.5 bar. It is not suitable for use as a direct water heater. Where potable water is required, a matching calorifier or plate heat exchanger must be provided in the system. Modulex is designed to operate with a Type B conventional flue, but models 100 to 340 can be installed as Type C room sealed twin flue appliances, with the air intake connected to the boiler casing.

### Statutory requirements

The installation and commissioning of the boiler must be carried out by a qualified engineer in accordance with the instructions provided.

Gas supplies and gas burners must be installed, serviced and commissioned by a qualified person, eg. a Gas Safe registered engineer.

### Handling

Offloading, dry storing and placing of equipment in the boiler room is the responsibility of the installer.

Equipment must be dry stored and protected from frost. Cartons must not be crushed or otherwise damaged.

### Commissioning

Clyde undertake commissioning of boilers. Commissioning charges do not include servicing during the guarantee period, although this may be carried out under service contract or to specific order. Boilers should be commissioned in line with CIBSE Commissioning Code B.

### Servicing

The importance of regular maintenance cannot be over-emphasised if maximum efficiency is to be maintained. Customers are strongly advised to place the equipment under service contract immediately commissioning is complete.

### Guarantee

Subject to correct handling, installation and operation, the boilers are guaranteed for two years from the date of despatch.

The guarantee is not valid if the boiler is not installed in accordance with these instructions (please refer to page 7), becomes blocked with debris and/or carbonate deposits from the system water and/or there is no documented evidence of commissioning by Clyde or their appointed engineer.

### Boiler Log book

A boiler log book that provides a permanent record of commissioning and servicing data and measurements is supplied with every boiler. It is recommended that the owner ensures that this log book is kept safe and brought up to date on every occasion that routine or emergency work is carried out on the boiler.

### Emitter sizing (radiators)

The boiler will operate in condensing mode whenever the return water is below 50°C and will reach its full potential if the flow water temperature is also below 50°C. However, the latter condition will mainly occur when the boiler is heating an underfloor heating scheme or transiently when recharging a DHW storage tank from cold. By careful design of a traditional heating system with radiators, and with weather compensating control in operation, the return water temperature can be held below 50°C for most of the heating season, only rising above this figure when outdoor temperatures are below zero.

For optimum performance, calculate heat losses on the basis of a 20°C internal temperature and a -8°C outdoor air temperature. With no added factors, size the radiators on the basis of published EN 442 data ( $\Delta T50$ ) and size the system pump for a 10°C temperature drop. In most cases this will ensure that the boiler begins to operate in condensing mode when the outdoor air temperature rises above 1°C and becomes fully condensing when the temperature is above 5°C. For heating schemes in buildings where the occupants have special needs, different environmental conditions may apply and further advice must be sought.

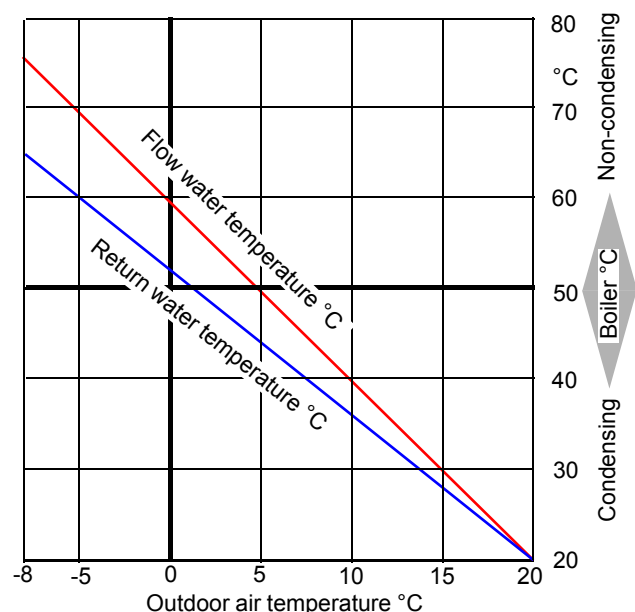

## Dimensions and technical data

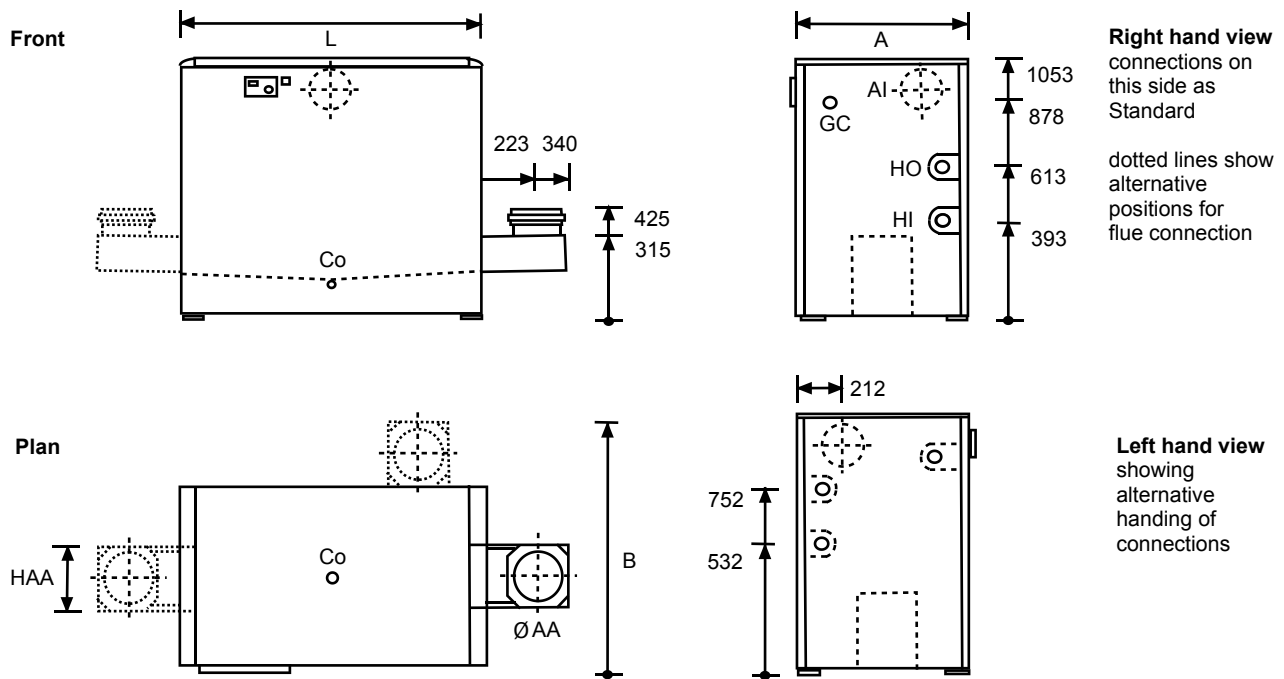

### Dimensions

Boiler model			100	145	190	240	290	340
Number of modules			2	3	4	5	6	7
Overall length	L	mm	695	695	834	968	1102	1236
Overall width	A	mm	695	695	695	695	695	695
Overall width with rear flue connection	B	mm	820	820	820	820	820	820
Boiler flow connection	HO	Rp	2					
Boiler return connection	HI	Rp	2					
Gas connection	GC	R	1½					
Flue spigot (inside dimension)	AA	DN	150	150	150	200	200	200
Flue diameter	HAA	mm	240					
Air intake	AI	mm	150					
Condensate drain	Co	mm	40					

### Technical data

Nominal heat output at;	30/50°C	kW	96	144	192	241	290	339
	60/80°C	kW	93	140	187	235	282	330
Efficiency at 100% load (ncv)	30/50°C	%	99.9	101.1	100.2	100.4	100.7	101
Efficiency at 30% load (ncv)	30/50°C	%	106.2	106.2	106.2	106.2	106.2	106.2
Boiler seasonal efficiency (1)		%	94.6	94.8	94.6	94.7	94.7	94.8
Input (ncv)		kW	96	144	192	240	288	336
Natural gas consumption (gross cv)		m³/h	10	14.9	19.9	24.9	29.9	34.9
Dry weight		kg	150	185	225	260	305	345
Water content		l	10.1	14.2	18.3	22.4	26.5	30.6
Max flue resistance		Pa	100					
Flue gas temperature rise (Max)	30/50°C	°C	49.1	47.2	44.8	43.1	41.2	40.1
Flue gas mass flow (Max)	30/50°C	kg/h	158.4	237.6	317	396	475	554.3
Flue gas temperature rise (Min)	30/50°C	°C	30.4	30.4	30.4	30.4	30.4	30.4
Flue gas mass flow (Min)	30/50°C	kg/h	20.2	20.2	20.2	20.2	20.2	20.2
CO <sub>2</sub> in flue gas (min / max)		%	8.6 / 9.1					
N0x (based on EN 297/A3)		Mg/kWh	52					
Maximum hydraulic working pressure		bar	6					
Minimum hydraulic working pressure		bar	0.5					
Sound level		dBA	<49					

Notes: (1) Calculated from the non-domestic heating and cooling compliance guide for conformance with ADL2A and

ADL2B 2006 using the formula  $\eta_{\text{seasonal}} = 0.81\eta_{30\%} + 0.19\eta_{100\%}$

(2) Refer to Clyde for data on Propane (G31) operation

### Water flow rates and hydraulic resistances

Water flow rate at 11°C temp. rise	l/s	2.09	3.13	4.17	5.24	6.3	7.37
Hydraulic resistance at 11°C temp. rise	kPa	35	44	55	68	90	120
Water flow rate at 20°C temp. rise	l/s	1.14	1.71	2.29	2.87	3.45	4.04
Hydraulic resistance at 20°C temp. rise	kPa	10	15	18	25	30	35

## Dimensions and technical data

### Modulex 440 only

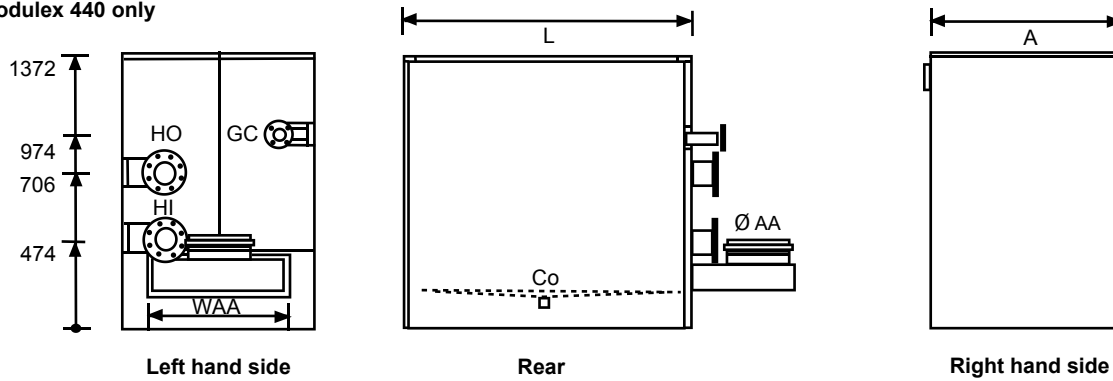

### Modulex 550 to 770

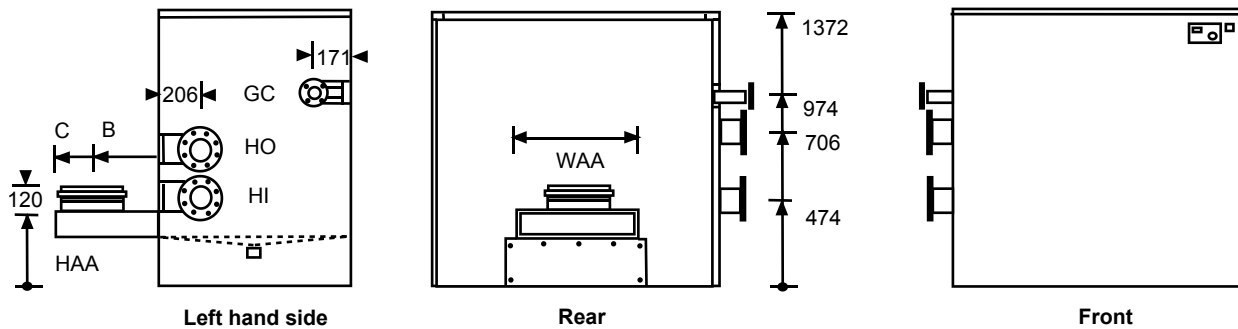

### Dimensions

Boiler model			440	550	660	770
Number of modules			4	5	6	7
Overall length	L	mm	1122	1122	1256	1390
Overall width	A	mm	920	920	920	920
Centre line of flue	B	mm	390	425	425	425
Flue connection projection	C	mm	545	600	600	600
Boiler flow connection	HO	mm	DN80	DN80	DN100	DN100
Boiler return connection	HI	mm	DN80	DN80	DN100	DN100
Gas connection	GC	mm	DN50			
Flue spigot (inside dimension)	AA	DN	250	250	300	300
Flue connector width	WAA	mm	615	615	721	855
Flue connector height	HAA	mm	310	310	310	310
Condensate drain	Co	mm	40			

### Technical data

Nominal heat output at;	30/50°C	kW	442	554	667	781
	60/80°C	kW	422	528	633	739
Efficiency at 100% load (ncv)	30/50°C	%	102.4	102.6	103	103.3
Efficiency at 30% load (ncv)	30/50°C	%	108.8	108.8	108.8	108.8
Boiler seasonal efficiency (1)		%	96.9	97.0	97.0	97.1
Input (ncv)		kW	432	540	648	756
Natural gas consumption (gross cv)		m <sup>3</sup> /h	44.8	56	67.2	78.4
Dry weight		kg	430	510	620	680
Water content		l	73	88	103	118
Max flue resistance		Pa	100			
Flue gas temperature rise (Max)	30/50°C	°C	52	51	50.6	52
Flue gas mass flow (Max)	30/50°C	kg/h	700	875	1049	1224
Flue gas temperature rise (Min)	30/50°C	°C	31	31	31	31
Flue gas mass flow (Min)	30/50°C	kg/h	36.4	36.4	36.4	36.4
CO <sub>2</sub> in flue gas (min / max)		%	9.0 / 9.2			
N0x (based on EN 297/A3)		Mg/kWh	47			
Maximum hydraulic working pressure		bar	6			
Minimum hydraulic working pressure		bar	0.5			
Sound level		dBA	<49			

Notes: (1) Calculated from the non-domestic heating and cooling compliance guide for conformance with ADL2A and

ADL2B 2006 using the formula  $\eta_{\text{seasonal}} = 0.81\eta_{30\%} + 0.19\eta_{100\%}$

(2) Refer to Clyde for data on Propane (G31) operation

### Water flow rates and hydraulic resistances

Water flow rate at 15°C temp. rise	l/s	7.04	8.82	10.62	12.44
Hydraulic resistance at 15°C temp. rise	kPa	28	34	38	52
Water flow rate at 20°C temp. rise	l/s	5.26	6.6	7.94	9.3
Hydraulic resistance at 20°C temp. rise	kPa	16	15	21	23

# Dimensions and technical data

## Modulex 900

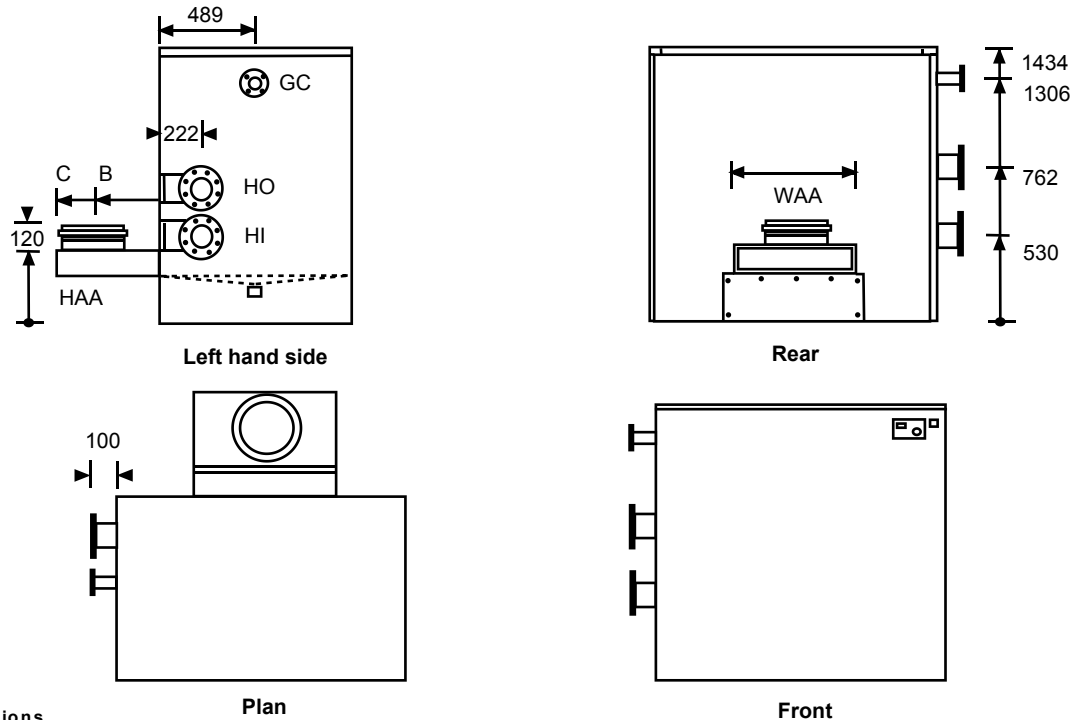

### Dimensions

			900
Boiler model			900
Number of modules			8
Overall length	L	mm	1674
Overall width	A	mm	961
Centre line of flue	B	mm	410
Flue connection projection	C	mm	585
Boiler flow connection	HO	mm	DN100
Boiler return connection	HI	mm	DN100
Gas connection	GC	mm	DN80
Flue spigot (inside dimension)	AA	DN	300
Flue connector width	WAA	mm	986
Flue connector height	HAA	mm	310
Condensate drain	Co	mm	40

### Technical data

Nominal heat output at;	30/50°C	kW	894
	60/80°C	kW	844
Efficiency at 100% load (ncv)	30/50°C	%	103.5
Efficiency at 30% load (ncv)	30/50°C	%	108.8
Boiler seasonal efficiency (1)		%	97.1
Input (ncv)		kW	864
Natural gas consumption (gross cv)		m <sup>3</sup> /h	89.5
Dry weight		kg	830
Water content		l	133
Max flue resistance		Pa	100
Flue gas temperature rise (Max)	30/50°C	°C	52
Flue gas mass flow (Max)	30/50°C	kg/h	1399
Flue gas temperature rise (Min)	30/50°C	°C	31
Flue gas mass flow (Min)	30/50°C	kg/h	36.4
CO <sub>2</sub> in flue gas (min / max)		%	9.0 / 9.2
NO <sub>x</sub> (based on EN 297/A3)		Mg/kWh	47
Maximum hydraulic working pressure		bar	6
Minimum hydraulic working pressure		bar	0.5
Sound level		dBA	<49

Notes: (1) Calculated from the non-domestic heating and cooling compliance guide for conformance with ADL2A and

ADL2B 2006 using the formula  $\eta_{\text{seasonal}} = 0.81\eta_{30\%} + 0.19\eta_{100\%}$

(2) Refer to Clyde for data on Propane (G31) operation

### Water flow rates and hydraulic resistances

Water flow rate at 15°C temp. rise	l/s	14.23
Hydraulic resistance at 15°C temp. rise	kPa	52
Water flow rate at 20°C temp. rise	l/s	10.64
Hydraulic resistance at 20°C temp. rise	kPa	26.5

# Installation requirements

## Regulations governing installation

Modulex boilers should be installed in accordance with all prevailing regulations and codes of practice, including the Building Regulations, Health and Safety Regulations PM5, Water Bylaws and the current Gas Safety (Installation and Use) Regulations. Detailed relevant guidance will also be found in;

BS 6644 :2005	Installation of appliances exceeding 70 kW net input
CIBSE AM14	Non-domestic hot water heating systems

CIBSE Guides B and C and Commissioning Code B  
Institution of Gas Engineers Utilization Procedures 1, 1A, 2, 4, 7 and 10.

## Water treatment

Modulex boilers have an aluminium alloy heat exchanger and care must be exercised to ensure that the system water and any water treatment is compatible. Whenever a new boiler is connected to an existing system, the pipework must be thoroughly cleaned and flushed. This is to remove debris, rust particles, carbonate deposits and any existing water treatment that might be incompatible with the heat exchanger. New systems must also be thoroughly flushed to remove debris and flux deposits. Clyde recommend that a permanent means of filtration be fitted into the return pipework, such as a sludge trap, hydrocyclone or full flow duplex filters. The boiler guarantee will be invalid if waterways are blocked by debris or carbonate deposits. The pH value of the system water should be measured to ensure that it is between 6.5 and 8. Temporary hardness (calcium carbonate and magnesium carbonate) can be removed by boiling and its effects limited by preventing ingress of fresh, untreated water. Permanent hardness (eg sulphates and chlorides) must not exceed 50 mg/litre. The boiler guarantee will be invalidated by the use of incorrect or incompatible water treatment. Specialist advice should be obtained, eg from;

Fernox Tel. 01483 793200

For full information on cleaning, flushing and protecting hot water systems, refer to BSRIA Application Guide AG 1/2001.

## Deaeration

It is essential that there is effective air removal from the system to avoid corrosion of the heat exchanger. If there is underfloor heating, oxygen-barrier pipe should be used or the boiler separated from the system by a plate heat exchanger.

## Boiler condensate

Modulex boilers have a 40mm condensate drain that is compatible with standard plastic waste pipe (ABS or PVCu). Do not use other materials, as they will corrode. The pipe size must not be reduced and there must be a continuous fall of at least 1:30 to drain. A condensate trap must be provided external to the boiler. As a further

precaution against freezing, condensate pipes should be run internally whenever possible and lagged when run externally.

## Pressurisation of systems

Modulex boilers should be installed as part of a pressurised (sealed) or open vented system with a minimum pressure of 0.5 bar. The maximum allowable pressure for the boilers is 6 bar. They are not to be used with a gravity system. If an open vented system is being used, it must be confirmed that static head and operating conditions will maintain the anti-flash margin.

## Boiler location

Modulex boilers will normally be installed inside a building. The boiler must be mounted on a sound, level and non-combustible raised plinth of at least 100mm, capable of supporting its weight. The boiler location must be frost-free and adequately ventilated (see below). Contamination of the combustion air by inflammable vapours, high dust levels or halogenated hydrocarbons will constitute a safety hazard and will damage the boiler.

The following minimum clearances around the boiler should be observed;

Front	600 mm
Sides	50 mm min on one side, flue connector depth (if fitted) + 300 mm on other
Rear	Flue connector depth (if fitted) + 300 mm
Above	600 mm

Alternatively, Modulex boilers may be installed external to the building, using a proprietary stainless steel shroud - refer to Clyde for details.

## Air supply and ventilation

Adequate air for combustion and ventilation is essential to the safe operation of a boiler. If the boiler is installed with a Type C room sealed flue, BS 6644:2005 calls for minimum ventilation of 2 cm<sup>2</sup> free area per kW net input at both high and low level unless the ambient temperature of the plant room ceiling exceeds 40°C.

When the installation comprises multiple boilers or single boilers above 70 kW net input with Type B flues, the ventilation requirements of either BS 6644:2005 or IGEN/UP/10 must be met. Table 1 shows the requirements of BS 6644:2005. This standard requires natural ventilation at both high and low levels to the outside air, and is based on the net input of the boilers.

Ventilation direct to outside air	Total kW input (net)
Low level	4 cm <sup>2</sup> per kW of total rated net input
High level	2 cm <sup>2</sup> per kW of total rated net input

**Table 1 Ventilation for single or multiple boiler installations in a boiler room complying with BS 6644:2005**

## Installation requirements

### Heat exchanger hydraulic resistance

The Modulex boiler has a high resistance heat exchanger. The boiler does not have an integral pump, but does require a minimum flow rate equivalent to  $\Delta T 20$ , as shown in the tables on pages 4 to 6. The boilers should be hydraulically separated from the heating distribution system by either a low velocity header or a plate heat exchanger and each boiler has an individual circulating pump. This will ensure the minimum flow rate at all times. With this arrangement, the boiler pump can be located in the return (where water temperature is lowest) regardless of the location of the system distribution pumps. A pump over-run should be provided via a relay.

### Low velocity headers

Low velocity headers are used to separate hydraulically the boilers from the rest of the system. In addition to helping maintain a minimum flow through the boiler, they create a low velocity region for system dirt to be deposited and separation of air from the system water. Used in conjunction with a system filter (refer page 7), they are invaluable when connecting a new boiler to an existing system.

Low velocity headers should always be vertical and sized for a maximum water velocity of 0.5 m/s. Modulex low velocity headers are designed to ensure a water velocity of 0.2 m/s or less and for  $\Delta T 10$  or 20, so will be suitable for most systems. Fig 2 proposes dimensions for the design of a low velocity header, and Table 2 shows dimensions for a  $\Delta T 10$  or 20 system.

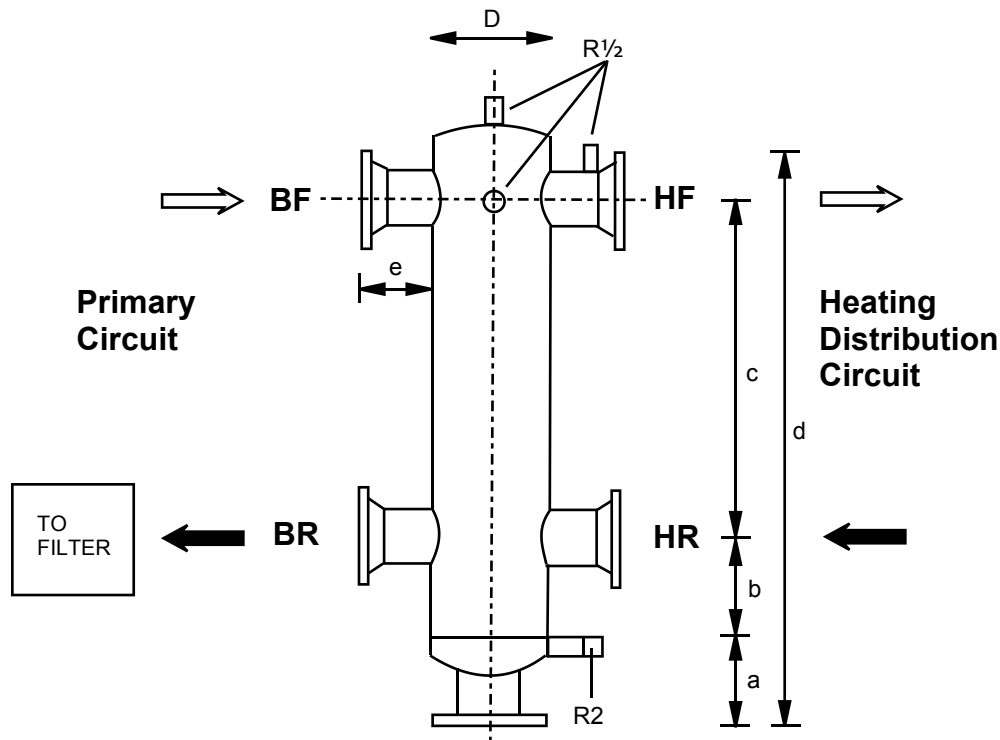

Fig 2 Design for a low velocity header

Max output (kW) $\Delta T 20 / \Delta T 10$	D mm $\Delta T 20$	D mm $\Delta T 10$	BF / BR $\Delta T 20 / \Delta T 10$	HF / HR $\Delta T 20 / \Delta T 10$	a mm	b mm	c mm	d mm	e mm
145*	140	150	DN65 PN16	DN65 PN16	200	300	1000	1650	200
550*	220	220	DN100 PN16	DN100 PN16	200	300	1000	1650	200
900*	400	400	DN150 PN16	DN150 PN16	275	300	1500	2275	200
< 3500 / 1750	500	500	250	250	300	400	1500	2500	200
< 4600 / 2300	600	600	300	300	300	400	1800	2800	200

Table 2 Low velocity header dimensions for  $\Delta T 10$  or 20 system

\*Note: These first three listed low velocity headers are available from Clyde  
The last two are suggested sizes for on-site fabrication



# Hydraulic system design

## General

Modulux boilers should be hydraulically separated from the heating system by either a low velocity header or plate heat exchanger. Any plastic pipework without an oxygen barrier should be separated from the boiler by a plate heat exchanger.

DHW calorifiers can be connected either side of the LVH, controlled by a loading pump on the primary or high temperature side (fig 4) or a loading pump on the distribution or low temperature side (fig 5). Alternatively, Modulux boilers can be used for heating-only applications, with external control of heating zones. Figs 4 and 5 show examples of connection to the E8 Regulator. More schematics are shown in the Installation and Servicing Instructions.

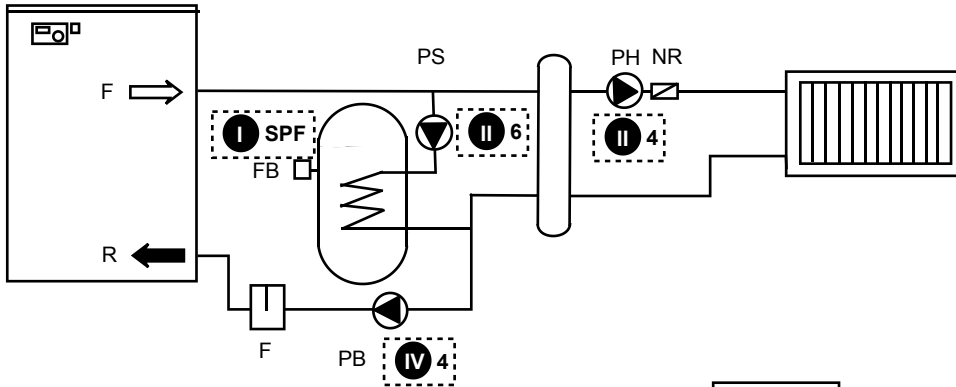

Fig 4 DHW calorifier on high temperature side

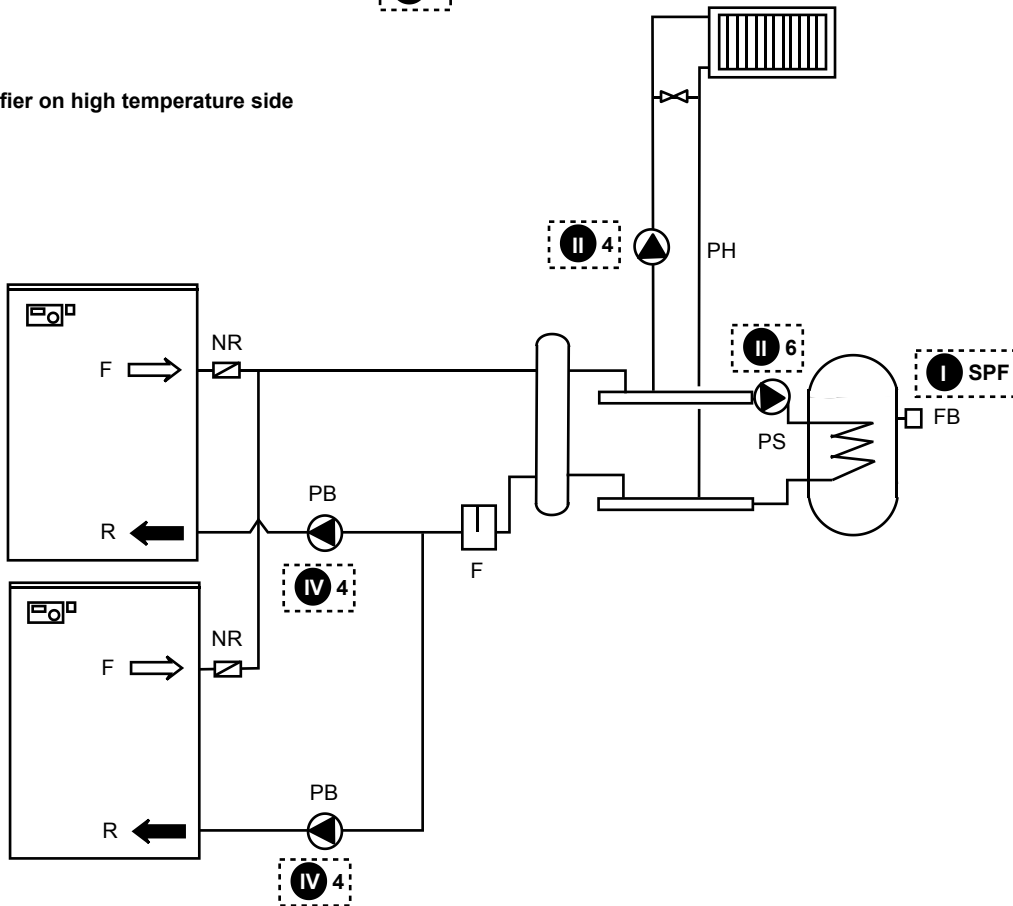

Fig 5 DHW calorifier on low temperature side

### Key to figs 4 and 5

- F Filter
- FB DHW sensor
- NR Non-return valve
- PB Boiler pump
- PH Heating Pump
- PS DHW loading pump

This publication is issued subject to alteration or withdrawal without notice. The illustrations and specifications are not binding in detail. All offers and sales are subject to the Company's current terms and conditions of sale, a copy of which is available on request.

---

**Clyde Energy Solutions Ltd**

Units 13 - 14 Charlwoods Rd  
East Grinstead  
West Sussex RH19 2HU  
t : 01342 305550  
f : 01342 305560  
e : [info@clyde4heat.co.uk](mailto:info@clyde4heat.co.uk)  
w : [clyde4heat.co.uk](http://clyde4heat.co.uk)



EDS 789/3  
July 2010